

2026

EAA[®]TOOLS

2026 H-60/S-70 SERIES TOOL CATALOG

eaatools.com

info@eaatools.com

480.420.4044



THIS SIDE OUT

EAA TOOLS

OFF

A MESSAGE FROM THE EAA TOOLS MANAGEMENT TEAM

WELCOME

Fellow Soldiers, Warfighters, Maintainers, End-Users and Operators,

EAA Tools was solely created to provide you a full line-up of unique H-60 Platform Special Hand Tools you have always hoped for, but have not been provided. We do not use the old OEM mentality of limited tooling support that you have to resolve; We provide tooling solutions from Real & Actual soldier needs, each with its own logical maintenance rationale to resolve a chronic maintenance issue, as defined by you. After listening to you and gleaning from your extensive maintenance experiences on the H-60, we offer you an array of downselected, best practices tool solutions. All have been meticulously designed and engineered, tested for precise form, fit and function. Our tools have been vetted by customer end-users (D-Co, AMXS, & MRO's alike) and approved by US Army Systems Readiness Directorate (SRD), so that you get the most durable, effective, efficient and applicable maintenance solution without any fluff or added footprint. Some of the tools have been invented, some of them re-designed and perfected. In the end, you are getting what you specifically need to accomplish your unique task and mission.

We are honored to be able to directly support. And we will continue to do so.

Very Respectfully,



Ed Elsner
President



CONTENTS

02	Welcome Message
04	H-60 Comprehensive Expeditionary Kit
06	H-60 Standard Expeditionary Kit
08	H-60 and S-70 Heavy Maintenance Kit
10	H-60 237 WP Peculiar Tool Kit
12	H-60 Flight Control Rigging Kit
14	H-60 Special Purpose Kits
14	H-60 M/R Head Kit
15	H-60 Bearings and Bushings Kit
16	H-60 XMSN Kit
16	H-60 Landing Gear Head Kit
16	H-60 Tail Rotor Pylon Kit
17	H-60 Blade Alignment Kit
18 / 36	H-60 Individual Support Tools
18 / 19	Airframe
20	Flight Controls
21	Service
21 / 22	Landing Gear
23 / 27	Main Rotor
27	Pilot Seat
28 / 30	Tail Rotor
30 / 31	Transmission
31	Generator
32	Flight Control Main Rotor
33	Air Frame Transmission
37	Notes
38	Our Quality Statement
39	Our Warranty



KITS

H-60 MAINTENANCE SOLUTION KITS

H-60 COMPREHENSIVE EXPEDITIONARY KIT

EAA Tools offers the H-60/S-70 Series Comprehensive Expeditionary Kit to ensure that all necessary tools are available as a deployable package to the Warfighter & End-user Maintainer, while providing a minimal tool footprint. The comprehensive expeditionary kit comes in MIL-SPEC Pelican 1730 containers with a Blade Lift Cradle add-on. This deployable package can easily be strapped into the aircraft. The kit contains most specialized tools to maintain the Blackhawk platform. The new EAA invented tools have been created to resolve maintenance issues, effectively and efficiently. Tools included in the kit are also derived from the legacy, locally manufactured tools from the US Army H-60 Work Packages. They have been dramatically improved upon from their original design. The other needed commercial tools that are not found in a general mechanic's tool box, are also included.

THE COMPREHENSIVE EXPEDITIONARY KIT SUPPORTS

Kits provide the operators and maintainers with capabilities for many H-60 environments.

- ◆ Initial deployment operations in zero to 19 hours by keeping the aircraft moving until logistics/Delta Company can reach the deployment location.
- ◆ DART Missions by enabling the mechanic to have the right tools to reach the needed repair area.
- ◆ Line Company footprint is dramatically reduced without sacrificing any scheduled maintenance inspections or component replacements.
- ◆ Delta company is supported by having the right tool to do a job efficiently and safely.
- ◆ Commercial customers have a complete tool room package on wheels.



CODE	ITEM
COMP A-60-AA	Expeditionary + PTK + AFL (L/G Model)
COMP B-60-AA	Expeditionary + PTK + AFL (M/V/W and S-70i Model)
COMP C-60-AA	Expeditionary + PTK + AFL (A and S-70 Model)
COMP D-60-AA	Expeditionary + PTK (A and S-70 Model)

CODE	ITEM
COMP E-60-AA	Expeditionary + PTK (L/G Model)
COMP F-60-AA	Expeditionary + PTK (M/V/W and S-70i Model)
BLC-60-AA	Blade Lift Cradle (Add-on for A/L/G and S-70 Model)



EAA  **TOOLS**®

COMPONENTS INCLUDED IN THE KIT

STANDARD EXPEDITIONARY

- ◆ Main Rotor Blade Alignment Tool
- ◆ Main Rotor Spindle Puller
- ◆ Tail Rotor Pitch Beam Puller
- ◆ Tail Rotor Pitch Beam Nut Spanner
- ◆ Tail Rotor Assembly Inspection Tool (Qty 2)
- ◆ Tail Rotor Star Plate
- ◆ Chip Detector Removal (Qty 2)
- ◆ Main Module XMSN Oil Filter Bowl Removal Tool
- ◆ Pylon Torque Adapter
- ◆ 3/8" Drive SAE 3/4" Low Profile Spline Torque Adapter
- ◆ Torque Adapter Set
- ◆ Main Module Installation Tool
- ◆ Flight Control Bearing Press
- ◆ Thin Wall 1/4" Drive, 3/8" Deep Well Socket
- ◆ Brake/Strut/Damper Servicing Kit
- ◆ 2-1/4" Socket, Main Landing Gear, with 1/2" Drive Adapter
- ◆ 1"-7/16" 1/2" Drive Socket Drive Landing Gear Strut
- ◆ Main Landing Gear Strut Pressure Gauge
- ◆ Main Leading Gear Strut Torque Adapter
- ◆ Tail Yoke Teflon Washer Alignment Jig
- ◆ MR Retaining Nut 20" 1/2" Dr Ext.
- ◆ Damper Spherical Bearing Press
- ◆ Fixture Brace for Bifilar Weights Bolts: 15/16" & 1-16"
- ◆ 9/16" Low Profile Socket for Lower Pressure Plate Bolts
- ◆ 3/4" Drive, 11/16" Socket for Main Module Hardware
- ◆ Torque Adapter for Pitch Change Rod
- ◆ Main Rotor Bushing Alignment Tool
- ◆ Spindle/Blade Cuff Washer Alignment Tool (Qty 8)
- ◆ Spindle Bearing Press
- ◆ Swashplate Scissor Bearing Press
- ◆ Threaded Insert Replacement Kit
- ◆ Pilot Seat Resilient Mount Press
- ◆ Turnbuckle Rigging Kit (Qty 2)
- ◆ Tail Rotor Quick Disconnect Wrench
- ◆ Main Mod Mount Bolt Torque Adapter
- ◆ Generator Spline Removal Tool
- ◆ Gearbox Seal Removal Tool
- ◆ Outboard Retention Plate Center Bushing

237WP PECULIAR TOOL KIT (PTK)

- ◆ Stabilator Position Sensor Limit Switch Lock pin
- ◆ Pitot-Static Power Cable Assembly
- ◆ Pitot-Static Tee Air Hose Assembly (AFCS)
- ◆ Pitot-Static Tee Air Hose Assembly (Pitot-Static/IFF)
- ◆ Phenolic Block
- ◆ Switch Panel Test Harness
- ◆ Input Module Flange Puller
- ◆ Blade De-Ice Test Harness
- ◆ Protractor Fixtures (A/L and M)
- ◆ Input Mod. (Input Seal) Installation Tool
- ◆ Main G/B (Output Seal) Installation Tool
- ◆ Int. G/B (Input/Output Seal) Installation Tool, Tail G/B (Input Seal) Installation Tool

- ◆ Tail G/B (Output Seal) Installation Tool
- ◆ Stabilator Bolt Removal Tool
- ◆ Tail Rotor Pivot Bearing Replacement Wrench
- ◆ Oil Pump Installation Tool
- ◆ 30/60/90 degree Wedge
- ◆ 5/85/90 degree Drag Beam Wedge
- ◆ Pitch Control Link Tool

ESSENTIAL AVIATION FOOT LOCKER (AFL) TOOLS

- ◆ Dial Torque Wrench 0-35 in lb
- ◆ Torque Wrench 30-150 ft/lb
- ◆ Torque Wrench 50-250 ft/lb
- ◆ Torque Wrench 100-1000 in/lb (Qty 2)
- ◆ Torque Wrench 10-50 in/lb
- ◆ Torque Wrench 40-200 in/lb (Qty 2)
- ◆ 0-.125" Dial Depth Gage - knife edge/needle
- ◆ Dial Caliper; 0-6"
- ◆ Universal Back Plunger Dial Indicator
- ◆ 1-3/16" SAE 4-way Angle Head Wrench
- ◆ 1-1/4 — 1-5/16" SAE 15 Degree Offset Low Torque Slimline Open End Wrench
- ◆ 1-1/2 — 1-5/8 SAE 15 Degree Offset Low Torque Slimline Open End Wrench
- ◆ 1-3/8 — 1-7/16" SAE 15 Degree Offset Low Torque Slimline Open End Wrench
- ◆ Spiral Screw Extractor Kit 5 PC
- ◆ 24oz Bronze Tip Hammer
- ◆ 8" Bronze Drift Punch
- ◆ 5-1/4" 3/8 Pin Punch
- ◆ 5-1/4" 5/16 Pin Punch
- ◆ 5-3/4" 1/4 Pin Punch
- ◆ 5-1/4" 7/32 Pin Punch
- ◆ 5-1/4" 3/16 Pin Punch
- ◆ 5" 5/32 Pin Punch
- ◆ 4-7/32 Pin Punch
- ◆ 4pc Miniature Pick Set
- ◆ 1/4" hex drive mini ratchet angled head
- ◆ 3/8" Drive SAE 7/8" Open-End Crowfoot Wrench
- ◆ 3/8" Drive SAE 1-5/8" Open -End Crowfoot Wrench
- ◆ 3/8" Drive SAE 1-11/16" Open -End Crowfoot Wrench
- ◆ 3/8" Drive SAE 1-5/16" Open -End Crowfoot Wrench
- ◆ Pliers Locking Curved 7"
- ◆ Scale Weighing 0-60lbs
- ◆ Scale Weighing 0-10lbs
- ◆ Wrench 1-1/16 ASD FP 12PT
- ◆ Handle Hinge 1/2 Dr 18-5/8
- ◆ Composite Cast Mallet 42oz
- ◆ 18" Adjustable Wrench
- ◆ Wrench 1-3/4" Thin
- ◆ 3/8" Drive Impact Driver
- ◆ Mallet Rawhide 12in L

CASES AND CUSTOM FOAM

H-60 STANDARD EXPEDITIONARY KIT

EAA Tools offers the H-60/S-70 Series Standard Expeditionary Kit to ensure that all necessary tools, whether locally made, invented, improved, and innovated, are available as one deployable package to the Warfighter & End-user Maintainer.

The kit is comprised of two MIL-SPEC Pelican 1730 containers, the A/L Model kit has the blade lift cradle add-on. They are designed as a portable substitute for the A92 tool kit to support the ever-changing deployment and work environments for the U.S. Military/USG. They are also built for most after-market commercial and Foreign Military and commercial operators that have a difficult time obtaining these special tools.

We have added tools to the Kits that are derived from the legacy, locally manufactured tools from the US Army H-60 Work Packages. They have been dramatically improved upon from their original design. The other needed commercial tools that are not found in a general mechanic's tool box, are also included. The new EAA invented tools have been created to resolve old maintenance issues, effectively and efficiently.



CODE	ITEM
EXPA-60-AA	Expeditionary Kit (A and S-70 Model)
EXPL-60-AA	Expeditionary Kit (L/G Model)
EXPM-60-AA	Expeditionary Kit (M/V/W and S-70i Model)

COMPONENTS INCLUDED IN THE KIT

- ◆ Blade Alignment Tool
- ◆ Main Rotor Spindle Puller
- ◆ Tail Rotor Pitch Beam Puller
- ◆ Tail Rotor Pitch Beam Nut Spanner
- ◆ Tail Rotor Assembly Inspection Tool (Qty 2)
- ◆ Tail Rotor Star Plate
- ◆ Chip Detector Removal (Qty 2)
- ◆ Main Module XMSN Oil Filter Bowl Removal Tool
- ◆ Pylon Torque Adapter
- ◆ 3/8" Drive SAE 3/4" Low Profile Spline Torque Adaptor
- ◆ Torque Adapter Set
- ◆ Main Module Installation Tool
- ◆ Flight Control Bearing Press
- ◆ Thin Wall 1/4" Drive, 3/8" Deep Well Socket
- ◆ Brake/Strut/Damper Servicing Kit
- ◆ 2-1/4" Socket, Main Landing Gear, with 1/2" Drive Adapter
- ◆ 1"-7/16" 1/2" Drive Socket Drive Landing Gear Strut
- ◆ Main Landing Gear Strut Pressure Gauge
- ◆ Main Leading Gear Strut Torque Adapter
- ◆ Tail Yoke Teflon Washer Alignment Jig
- ◆ MR Retaining Nut 20" 1/2" Dr Ext.
- ◆ Damper Spherical Bearing Press
- ◆ Fixture Brace for Bifilar Weights Bolts: 15/16" & 1-16"
- ◆ 9/16" Low Profile Socket for Lower Pressure Plate Bolts
- ◆ 3/4" Drive, 11/16" Socket for Main Module Hardware
- ◆ Torque Adapter for Pitch Change Rod
- ◆ Main Rotor Bushing Alignment Tool
- ◆ Spindle/Blade Cuff Washer Alignment Tool (Qty 4)
- ◆ Spindle Bearing Press
- ◆ Swashplate Scissor Bearing Press
- ◆ Threaded Insert Replacement Kit
- ◆ Pilot Seat Resilient Mount Press
- ◆ Turnbuckle Rigging Kit (Qty 2)
- ◆ Tail Rotor Quick Disconnect Wrench
- ◆ Main Mod Mount Bolt Torque
- ◆ Generator Spline Removal Tool
- ◆ Gearbox Seal Removal Tool
- ◆ Outboard Retention Plate Center Bushing Tool
- ◆ 3/8" Drive SAE 7/8" Open-End Crowfoot Wrench
- ◆ 3/8" Drive SAE 1-5/16" Open-End Crowfoot Wrench
- ◆ 3/8" Drive SAE 1-5/8" Open-End Crowfoot Wrench
- ◆ 3/8" Drive SAE 1-11/16" Open-End Crowfoot Wrench
- ◆ Pitch Control Link Tool
- ◆ Stabilator Bolt Removal Tool
- ◆ Blade Lift Cradle (included in A/L models only)

CASES AND CUSTOM FOAM



EAA  **TOOLS**®

H-60 AND S-70 HEAVY MAINTENANCE KIT



EAA Tools offers the Heavy Maintenance Kit for the H-60 and S-70 platform, specifically customized for addressing the most common unscheduled and corrective Field Level maintenance tasks that occur between the Phase Inspections, and during mobilized duty deployments and field operations. Specific tools were carefully selected and dense-packed into one deployable 1730 Pelican custom case and foam configuration for ease of storage and accountability.

OVERALL DETAILS

- ◆ Down-selected tools from the PMI I & II Expeditionary Kit to cover the most common unscheduled >120 hour, corrective Field Level maintenance tasks and service operations for the H-60 and S-70 platform in one deployable, inventoriable dense pack configured 1730 Pelican case.
- ◆ All tools are made from the highest quality materials and MIL-SPEC anti-corrosion coatings and packaging.
- ◆ All tools incorporate key functional improvements over legacy tool solutions.
- ◆ Kit is delivered in a Pelican 1730 case with a custom 4lb closed cell, oil and shock resistant, anti static contrasting red/charcoal color for easy inventory.



CODE

HMK-60-EA

ITEM

Field Heavy Maintenance Kit (H-60 & S-70 Platform)



COMPONENTS INCLUDED IN THE KIT

- ◆ Pitch Control Link Tool
- ◆ Tail Rotor Assembly Inspection Tool
- ◆ Tail Rotor Pitch Beam Spanner
- ◆ Tail Rotor Cable Quick Disconnect
- ◆ Crowsfoot Socket Wrench Set
 - ◆ 1-5/8" Wrench; 3/8" Drive
 - ◆ 1-11/16" Wrench; 3/8" Drive
 - ◆ 1-5/16" Wrench; 3/8" Drive
 - ◆ 7/8" Wrench; 3/8" Drive
- ◆ Lock Pin Ratchet Flare Nut Wrench, 7/8in.
- ◆ Spindle And Blade Cuff Washer Alignment Tool
 - ◆ Press
 - ◆ Blade Insert
 - ◆ Spindle Insert
- ◆ Drive Line Torque Reactor
 - ◆ Drive Line Torque Plate
 - ◆ Drive Line Socket
- ◆ Tail Rotor Pivot Bearing Replacement Wrench
- ◆ Pitch Change Rod Torque Adapter
- ◆ 9/16 Low Profile Socket For Lower Pressure Plate Bolts; 3/8 Drive
- ◆ Generator Spline Removal Tool
- ◆ Oil Filter Bowl Removal Tool
- ◆ Chip Detector Removal Tool
- ◆ Gear Box Seal Removal & Installation Kit
 - ◆ Input Module (Input Seal) Installation Tool
 - ◆ Main G/B (Output Seal) Installation Tool
 - ◆ Int. G/B (Input/Output Seal) & Tail G/B for Input and Output Seal Installation Tool
 - ◆ Strike Plate
 - ◆ Bushing Guide
 - ◆ Spline Guard
 - ◆ Slide Hammer Body
- ◆ Blade Alignment Tool
- ◆ Main Rotor Bushing Alignment Tool
 - ◆ Tool A
 - ◆ Tool B
 - ◆ Tool C
 - ◆ Tool D
- ◆ Tail Yoke Teflon Washer Alignment Jig
- ◆ Swashplate Scissor Bearing Press
 - ◆ Removal Tool
 - ◆ Install Tool
- ◆ Damper Spherical Bearing Press
- ◆ Tail Rotor Star Plate
- ◆ Brake/Strut/Damper Service Kit
- ◆ Tail Rotor Pitch Beam Puller
 - ◆ Body
 - ◆ Handle

CASES AND CUSTOM FOAM

H-60 237WP PECULIAR TOOL KIT (PTK)

This procurable, commercial-off-the-shelf solution replaces the discontinued PTK (HET-6002PTK-101). The EAA Tools H-60 237WP Peculiar Tool Kit (PTK-60-AA), or PTK, provides a procurable and inventoriable tool kit to replace the issued PTK, which is no longer commercially available. The PTK comprises specialized field-level items and tools compatible with the specifications found in the UH-60 series Technical Manuals (TM1-1520 237-23&P). EAA Tools has updated each PTK item with key usability and durability improvements not found in either the TM nor the previously marketed version.

All the special peculiar tools included are guaranteed for quality and performance by EAA Tools, relieving the user from the burden of fabricating his or her own solution.



OVERALL DETAILS

- ◆ Contains all the original WP special/peculiar heavy maintenance tools in one inventoriable MIL-SPEC case.
- ◆ Designed for H-60 mechanics and technicians to perform major H-60 scheduled/unscheduled FIELD level maintenance tasks at the Maintenance Company level (this is not an Expeditionary Line Company Kit, which EAA Tools also has).
- ◆ Procurable, commercial off the shelf solution, replacing the discontinued PTK (HET-6002PTK-101).
- ◆ All the special peculiar tools are made to EAA Tools' exacting standards, preventing the need to make the special tools individually at a local machine shop.



CODE	ITEM
PTK-60-AA	237 WP PTK



COMPONENTS INCLUDED IN THE KIT

- ◆ Stabilator Position Sensor Limit Switch Lock Pin
- ◆ Pitot-Static Power Cable Assembly
- ◆ Pitot-Static Tee Air Hose Assembly (AFCS)
- ◆ Pitot-Static Tee Air Hose Assembly (Pitot-Static/IFF)
- ◆ Phenolic Block
- ◆ Miscellaneous Switch Panel Test Harness
- ◆ Module Flange Puller
- ◆ Blade De-Ice Test Harness
- ◆ Protractor Fixture A/L to Protractor Fixture
- ◆ Seal Installation Tools
- ◆ Input Mod. (Input Seal) Installation Tool
- ◆ Main G/B (Output Seal) Installation Tool
- ◆ Int. G/B Input/Output Seal Installation Tool
- ◆ Tail G/B (Input Seal) Installation Tool
- ◆ Tail G/B (Output Seal) Installation Tool
- ◆ Spherical Bearing Remover/installer
- ◆ Stabilator Bolt Removal Tool
- ◆ Flight Control Cable Quick Disconnect Wrench
- ◆ Tail Rotor Pivot Bearing Replacement Wrench
- ◆ Oil Pump Installation Tool
- ◆ Main Transmission Mounting Bolt Adapter
- ◆ 30/60/90 degree Wedge
- ◆ 5/85/90 degree Drag Beam Wedge
- ◆ Pitch Control Link Tool
- ◆ Rotor Brake Torque Adapter
- ◆ Fixture Brace for Bifilar Weights Bolts: 15/16" & 1-16"
- ◆ Spindle and Blade Cuff Washer Alignment Tool

CASE AND CUSTOM FOAM

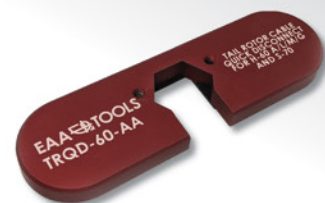

EAA TOOLS®

H-60 FLIGHT CONTROL RIGGING SYSTEM

EAA Tools offers the H-60 Flight Control Rigging System (FCRS-60-AA) to perform flight control rig and inspection. The pin set comprises special pins and tools that match the OEM specifications (including the M-model compatible F-Pin) required to rig H-60 flight controls. EAA has additionally developed a kit of rigging accessories, including a novel trammeling solution to set each hydraulic flight control rod to nominal length immediately prior to installation. All pins are ground to precise dimensions and fit is guaranteed. All manufacturing processes conform to relevant MIL, ASTM, ASME, or SAE specification.



OVERALL DETAILS

- ◆ All parts use hardened alloy steel construction
- ◆ All pins are ground to precise dimensions and fit is guaranteed
- ◆ All parts are finished and plated to prevent wear and corrosion
- ◆ All manufacturing processes conform to relevant Mil specification

FLIGHT CONTROL RIGGING KIT (FCRK-60-AA) HIGHLIGHTS:

- ◆ Additional "F Pins" for Mike models included
- ◆ Kit clearly labeled for easy inventory

FLIGHT CONTROL RIGGING ACCESSORY KIT (FCRA-60-AA) HIGHLIGHTS:

- ◆ All parts that the user expects from a Rig Accessory Kit
- ◆ Improved Spring Wedge is less likely to damage Collective Balance Spring
- ◆ Improved Gauges are precision milled and certified using NIST-traceable calibrated gauges
- ◆ Improved Tail Rotor Control Rod tool for speed and reliability

TRAMMEL HIGHLIGHTS:

- ◆ Sets each Control Rod to nominal length
- ◆ Speedy, portable, hand-held operation
- ◆ Compatible with 11 control rods
- ◆ Simple, repeatable, and precise (+/- .015")



CODE	ITEM
FCRS-60-AA	Flight Control Rigging and Accessory Kits
FCRK-60-AA	Flight Control Rigging Kit
FCRA-60-AA	Flight Control Rigging Accessory Kit



COMPONENTS INCLUDED IN THE KIT

FLIGHT CONTROL RIGGING KIT (FCRK-60-AA) INCLUDES:

- ◆ Pin Ground Safety (Upper Broom Closet)
- ◆ Pin Ground Safety (Lower Broom Closet)
- ◆ Pin Pitch Lock (Walking Beam)
- ◆ Pin Pitch Lock (Bellcrank Support)
- ◆ Pin Ground Safety (Yaw Pedal Adjuster)
- ◆ Pin Ground Safety (Stab Switch and Synchro)
- ◆ Pin Ground Safety (Mixer Yaw)
- ◆ Pin Ground Safety (Torque Shaft)
- ◆ Pin Ground Safety (Cyclic Stick Pitch)
- ◆ Block Rigging, Main Rotor Head (Damper Blocks)
- ◆ Pin Ground Safety (Yaw/Servo Control)
- ◆ Pin Ground Safety (Pitch/Roll Servo)
- ◆ Pin Ground Safety (Cyclic Stick Roll)
- ◆ Pin Ground Safety (Tail Rotor Servo)
- ◆ Pin Assembly Rigging (Mixer)

FLIGHT CONTROL RIGGING ACCESSORY (FCRA-60-AA) INCLUDES:

- ◆ Low Collective Gauge
- ◆ Primary Servo/Swashplate Gauge
- ◆ Nominal Trammel
- ◆ Spring Cylinder Clamp
- ◆ Digital Protractor Leveling Plate
- ◆ Tail Rotor Control Rod Tool
- ◆ Lds/Pas Alignment Tool (3.5")
- ◆ Tail Rotor Cable Turnbuckle Tool
- ◆ PCL Alignment Tool (6.5")
- ◆ Roll/Coll Rig Pin Alignment Tool
- ◆ Tail Rotor Quick Disconnect Tool
- ◆ Flight Control Bearing Press

CASE AND CUSTOM FOAM

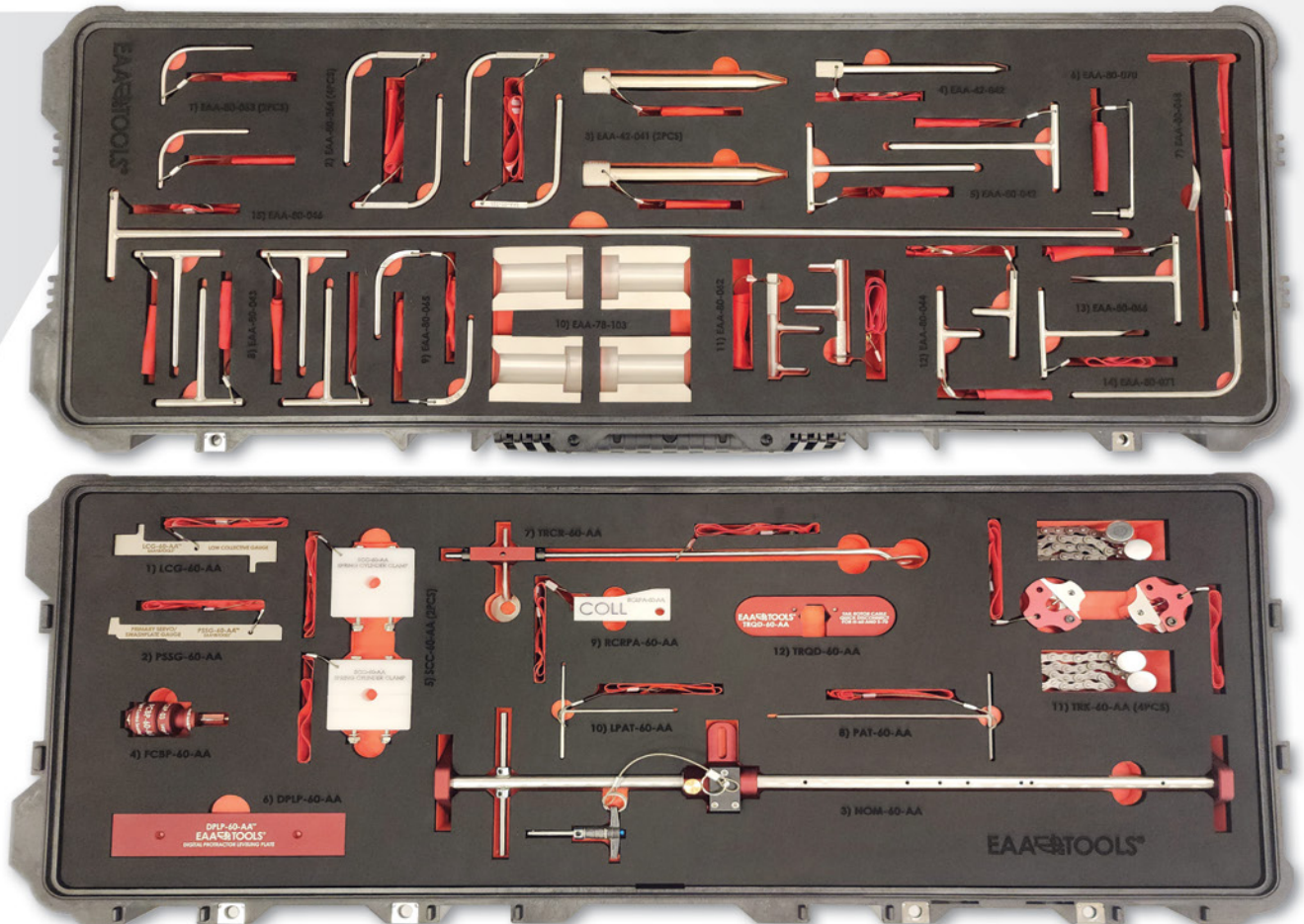

H-60 AND S-70 SPECIAL PURPOSE KITS

The Special Purpose Kits for H-60/S-70 by EAA Tools each contain a selection of carefully chosen, designed and configured peculiar hand tools, each engineered to exacting standards that provides a force multiplier and force projection in a small footprint. The Kits are each targeted to a specific part of the airframe and may be purchased, inventoried, and checked out as a set for the service of a particular aircraft system.



H-60 AND S-70 MAIN ROTOR HEAD KIT

- ◆ Covers the most common main rotor head service operations on the H-60 / S-70i.
- ◆ All tools made with the highest quality materials and MILspec anti-corrosion coatings.
- ◆ All tools incorporate key usability improvements over legacy solutions.
- ◆ Kit is delivered in Pelican case with custom foam insert

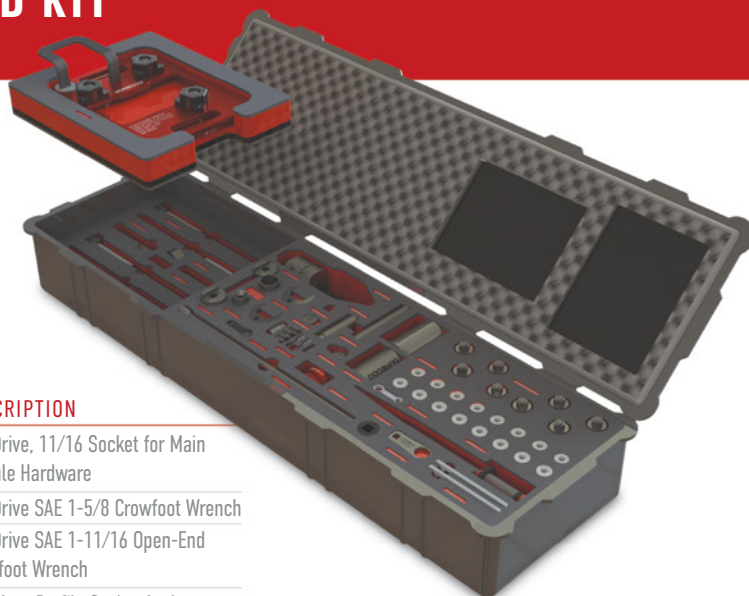

KIT COMPONENTS

#	PN	DESCRIPTION	#	PN	DESCRIPTION
1	SP-60-AA	Spindle Puller	11	MMS-60-AA	3/4 Drive, 11/16 Socket for Main Module Hardware
2	DSBP-60-AA	Damper Spherical Bearing Press	12	CFS1-60-AA	3/8 Drive SAE 1-5/8 Crowfoot Wrench
3	RBAT-60-AA	Main Rotor Bushing Alignment Tool	13	CFS2-60-AA	3/8 Drive SAE 1-11/16 Open-End Crowfoot Wrench
4	SBCAT-60-AA	Spindle & Blade Cuff Washer Alignment Tool (Qty 8)	14	LPP-60-AA	9/16 Low Profile Socket for Lower Pressure Plate Bolt
5	SBP-60-AA	Spindle Bearing Press	15	DE-60-AA	Main Rotor Retaining Nut 20 1/2 Drive Extension
6	SSBP-60-AA	Swashplate/Scissor Bearing Press	16	SMTA-60-AA	3/8" Drive SAE 3/4" Low Profile Spline Torque Adapter
7	PRTA-60-AA	Pitch Change Rod Torque Adapter	17	EAA-MRK-PKG	Case and Custom Foam
8	FBBW-60-AA	Fixture Brace for Bifilar Weights Bolts			
9	BAT-60-AA	Main Rotor Blade Alignment Tool			
10	TIRK-60-AA	Threaded Insert Replacement Kit			

PN: MRK-60-AA



PN: BBK-60-AA

H-60 AND S-70 BEARING AND BUSHING KIT

- ◆ R&I the most commonly serviced bushings and bearings on the H-60 / S-70.
- ◆ All tools made with the highest quality materials and MILSpec anti-corrosion coatings.
- ◆ All tools incorporate key usability improvements over legacy solutions.
- ◆ Kit is delivered in Pelican case with custom foam insert

KIT COMPONENTS

#	PN	DESCRIPTION
1	DSBP-60-AA	H-60 Damper, Spherical Bearing Press
2	RBAT-60-AA	H-60 Main Rotor Bushing Alignment Tool
3	FCBP-60-AA	H-60 Flight Control Bearing Press
4	SBP-60-AA	H-60 Spindle Bearing Press
5	SSBP-60-AA	H-60 Swashplate/Scissor Bearing Press
6	RMP-60-AA	H-60 Pilot Seat Resilient Mount Press - A/L model only
7	PCLT-60-AA	H-60 Pitch Control Link Tool
8	EAA-BBK-PKG	Case and Custom Foam



H-60 AND S-70 XMSN KIT

- ◆ Covers the most common transmission service operations on the H-60 / S-70i.
- ◆ All tools made with the highest quality materials and MILSpec anti-corrosion coatings.
- ◆ All tools incorporate key usability improvements over legacy solutions.
- ◆ Kit is delivered in Pelican case with custom foam insert

KIT COMPONENTS

#	PN	DESCRIPTION
1	ZBAR-60-AA	H-60 Main Module Hardware Installation Tool
2	CDR-60-AA	H-60 XMSN Chip Detector Removal Tool (Qty 2)
3	FBR-60-AA	H-60 Main Mod XMSN Oil Filter Bowl Shut Off/Rem. Tool
4	PRTA-60-AA	H-60 Pitch Change Rod Torque Adapter
5	RBTA-60-AA	H-60 AFT Main Mod Mount Bolt Torque Adapter
6	MMS-60-AA	H-60 3/4 Drive, 11/16 Socket for Main Module Hardware
7	SRT-60-AA H-60	Generator Spline Removal Tool
8	EAA-XMSK-PKG	Case and Custom Foam

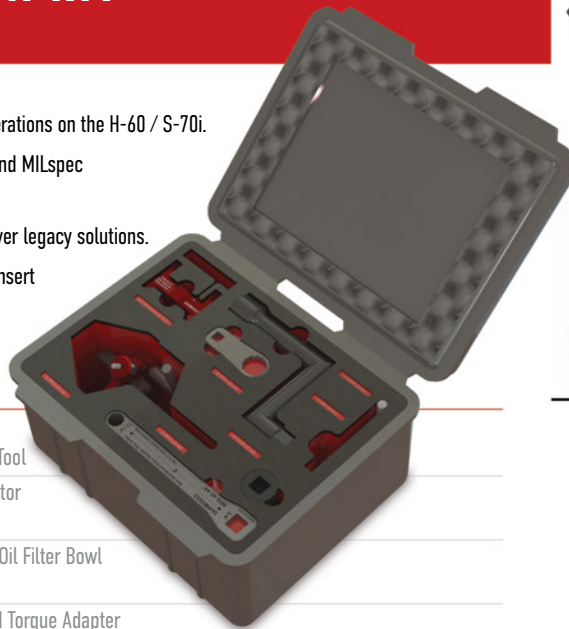

PN:
XMSKA-60-AA
OR
XMSKLM-60-AA



H-60 AND S-70 LANDING GEAR KIT

- ◆ Covers the most common landing gear service operations on the H-60 / S-70i.
- ◆ All tools made with the highest quality materials and MILspec anti-corrosion coatings.
- ◆ All tools incorporate key usability improvements over legacy solutions.
- ◆ Kit is delivered in Pelican case with custom foam insert.

KIT COMPONENTS

#	PN	DESCRIPTION
01	STA-60-AA	H-60 Main Landing Gear Strut Torque Adapter
02	SPG-60-AA	H-60 Main Landing Gear Strut Pressure Gauge
03	TYT-60-AA	H-60 Tail Yoke Teflon Washer Alignment Jig
04	MLGS-60-AA	H-60 Main Landing Gear 2-1/4 Socket and Adapter
05	SLGS-60-AA	H-60 1-7/16 1/2 Drive Socket for Landing Gear Strut
06	BSD-60-AA	H-60 Brake-Strut-Damper Servicing Kit
07	EAA-LGK-PKG	Case and Custom Foam



PN: LGK-60-AA

H-60 AND S-70 TAIL ROTOR PYLON KIT

- ◆ Covers the most common tail rotor and pylon service operations on the H-60 / S-70i.
- ◆ All tools made with the highest quality materials and MILspec anti-corrosion coatings.
- ◆ All tools incorporate key usability improvements over legacy solutions.
- ◆ Kit is delivered in Pelican case with custom foam insert.

KIT COMPONENTS

#	PN	DESCRIPTION	#	PN	DESCRIPTION
01	PBP-60-A	H-60 Tail Rotor Pitch Beam Puller	09	PBRW-60-AA	Tail Rotor Pivot Bearing Replacement Wrench
02	TRSP-60-AA	H-60 Tail Rotor Star Plate	10	PF-60-AA	H-60 Protractor Fixture
03	TRAIT-60-AA	H-60 Tail Rotor Assembly Inspection Tool (Qty 2)	11	SBRT-60-AA	H-60 Stabilator Bolt Removal Tool
04	PBS-60-AA	H-60 Tail Rotor Pitch Beam Nut Spanner	12	SLP-60-AA	H-60 Stabilator Position Sensor Limit Switch Lockpin
05	SCC-60-AA	H-60 Spring Cylinder Clamp	13	EAA-TAS-03	9/16" Torque Adapter
06	TRQD-60-AA	H-60 Tail Rotor Quick Disconnect Wrench	14	CBP-60-AA	H-60 Outboard Retention Plate Center Bushing
07	TRK-60-AA	H-60 Turnbuckle Rigging Kit (Qty 2)	15	EAA-TRPK-PKG	Case and Custom Foam
08	PTA-60-AA	H-60 Tail Pylon Torque Adapter			



PN: TRPKAL-60-AA, TRPKM-60-AA

01



02



PN: BAK-60-AA

H-60 AND S-70 BLADE REMOVAL KIT

- ◆ Includes Lifting Cradle and Alignment Stake to perform blade R&I operations on the H-60A and S-70.
- ◆ All tools made with the highest quality materials and MILSpec anti-corrosion coatings.
- ◆ All tools incorporate key usability improvements over legacy solutions.
- ◆ Kit is delivered in Pelican case with custom foam insert.

KIT COMPONENTS

#	PN	DESCRIPTION
01	BLC-60-AA	H-60 Main Rotor Blade Lift Cradle
02	BAT-60-AA	H-60 Main Rotor Blade Alignment Tool
03	EAA-BAK-PKG	Case and Custom Foam

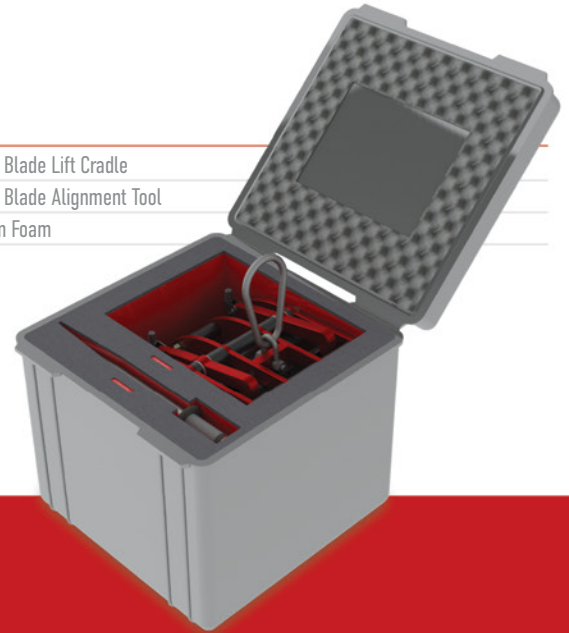

H-60 AND S-70 GEARBOX SEAL R&I KIT

- ◆ Offers the improved slide hammer Gearbox Seal Puller (GBSP-60-AA) designed to effectively remove the seal.
- ◆ Provides the Seal Installation Tools (SITs) for the Intermediate and Tail Rotor Input and Output seals.
- ◆ Adds important peripherals:
 - ◆ Center Strike Plate to facilitate seal installation using the SITs.
 - ◆ Delrin Spline Guards to prevent damage to the gear spline and Center Bushing Guide to prevent wobble to the SITs while installing the seals.

KIT COMPONENTS

#	PN	DESCRIPTION
01	GBSP-60-EA	Gear Box Seal Puller, Assy
02	EAA-SG-EA	Spline Guard, Delrin
03	SIT-60-EA	GBSK Seal Inst Tool
	EAA-SIT-01	Input Module Input Seal Inst Tool
	EAA-SIT-02	Main Gearbox Output Seal Tool
	EAA-SIT-03	Intermediate Gearbox Input Seal Tool
04	EAA-SP-EA	Strike Plate, Center
05	EAA-BG-EA	Bushing Guide, SIT
06	EAA-GBSK-PKG	1520 Pelican Custom Case & Foam



PN: GBSK-60-EA



H-60 AND H-70 AVIONICS MAINTENANCE KIT

- ◆ Covers the main H60/S70 specific avionics inspection tasks associated with the Stabilator system Sensors, Controls, Gyros, Blade De-Ice, and Pitot-Static, AFCS and IFF tests.
- ◆ Added Pitot-Static Test Adapters (2EA; P/N PSS59101-4-6-6, NAV-AIDS, LTD) to connect ground test equipment to the aircraft's Pitot and static ports/probes to verify that the airspeed and altitude systems are working correctly; pressure and vacuum, leak checks, and calibration of flight instruments.
- ◆ Kit is delivered in a Pelican case with custom foam insert.

KIT COMPONENTS

#	PN	DESCRIPTION	QTY
01	PF-60-AA	Protractor Fixture	1
02	WDGE-60-AA	30/60/90 (degree) Wedge	1
03	SLP-60-AA	Stabilator Position Lock Pin	1
04	DBW-60-AA	5/85/90 (degree) Drag Beam Wedge	1
05	BDITB-60-AA	Blade De-Ice Test Block	1
06	PST2-60-AA	Pitot Static Air Hose Assembly (AFCS)	1
07	PST3-60-AA	Pitot Static Air Hose Assembly (IFF)	1
08	PSA-60-EA	Pitot Static Test Adapter (NAV-AIDS, LTD)	2

PN: AMK-60-EA



INDIVIDUAL SUPPORT TOOLS

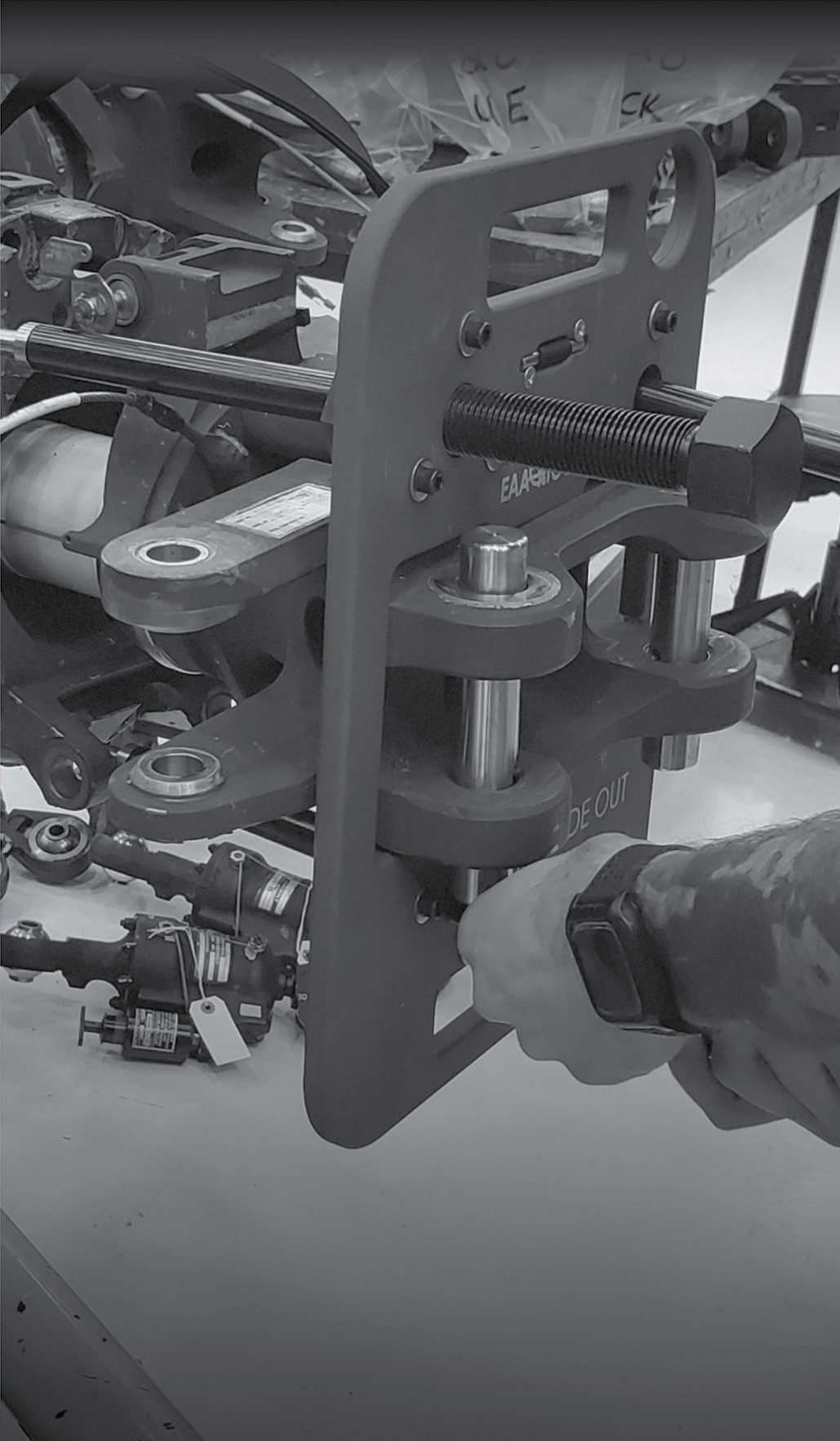

EAA Tools takes great care to ensure exacting quality in EAA manufactured solutions and EAA procured commercial tools. EAA manufactured solutions are fabricated from American Society for Testing and Materials (ASTM)-certified materials and alloys, then finished with processes and coatings conforming to MIL specifications. All EAA products are quality checked for performance and safety at several points before leaving the facility.

EAA Tools currently offers 49 individual tools for H-60/S-70 series helicopter. Many of EAA Tools' products are the only special tool available for a maintenance task, e.g. CDR-60-AA, EAA Tools' Main Mod Sump Chip Detector Removal Tool.

MAIN MODULE HARDWARE INSTALLATION TOOL (ZBAR)



PN: ZBAR-60-AA

Manufacturer: EAA Tools

EAA ZBAR is used to apply torque to the Main Module Mount Hardware under FWD Bell-Crank Support.

- Black Oxide coated for corrosion prevention per MIL-STD.

Aircraft Application: H-60 A/G/L/M/V/W, S-70+/S-70i

System: Main Module Mount

Maintenance Level (US Army): FIELD

Material: Hardened 4140 Alloy Steel

Country of Origin: USA

Weights/Dimensions:

WT: 2.3 lbs

Size: 9.5" L x 5.5" W x 1" D



AIRFRAME

TAIL PYLON BOLT TORQUE ADAPTER SET



PN: PTA-60-AA

Manufacturer: EAA Tools

EAA Tail Pylon Bolt Torque Adapter is used to install the Tail Pylon Bolts to Required Torque Specifications.

- Re-engineered to resolve the interference/clearance issues with Pylon A & B hydraulic lines while also providing a longer throw to clear and avoid damage to the Tail Strut access panel.
- Stenciled calculation of the offset is provided and laser-etched on the tool for easy calculations.
- Nickel plated for corrosion prevention per MIL-STD.

Aircraft Application: H-60 A/G/L/M/V/W, S-70+/S-70i

System: Tail Pylon

Maintenance Level (US Army): FIELD

Material: Hardened 4140 Alloy Steel

Weights/Dimensions:

WT: 1.8 lbs

Size: 4" L x 3" W x 3" D

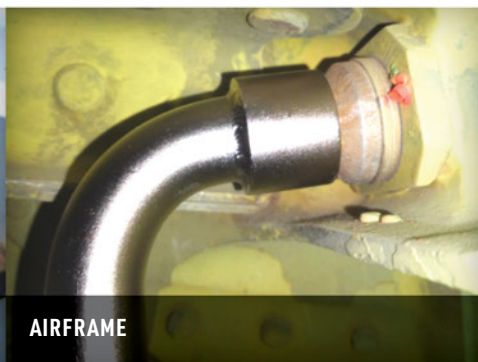

AIRFRAME

TORQUE ADAPTER SET



PN: TAS-60-AA

Manufacturer: Snap-On

Common size Torque Adapters (3/8" Drive; 3/8", 7/16", 9/16", 12 point) for various aircraft hardware.

Finish: Full Polish

Standards: SAE AS4984A

Aircraft Application: H-60 A/G/L/M/V/W, S-70+/S-70i

System: Tail Rotor Pitch Beam Assembly Removal

Maintenance Level (US Army): FIELD

Country of Origin: USA

Weights/Dimensions:

WT: 0.4 lbs

Size: 2.5" L x 0.6" W x 0.5" D



AIRFRAME

MAIN ROTOR SPINDLE MOUNT BOLT TORQUE ADAPTER



PN: SMTA-60-AA

Manufacturer: Snap-On

Perform 9-11 Torque Check on two 3/4" Spindle Bolts under the Anti-Flap Stop. 3/8" Drive SAE 3/4.

- 910-1010 in-lb working torque.
- Precision-crafted from special alloy steel and heat treated for optimum strength and durability.
- Machined from 4140 case-hardened machine tool steel, Electroless Nickel coated.
- Unique spline wrenching configuration can be used on ordinary 6 and 12 point fasteners.
- Ideal for use with torque wrenches.

Aircraft Application: H-60 A/G/L/M/V/W, S-70+/S-70i

System: Main Rotor Spindle Bolt Torque

Maintenance Level (US Army): FIELD

Country of Origin: USA

Weights/Dimensions:

WT: 0.2 lbs

Size: 3"L x 1.2"W x 0.5"D



AIRFRAME

FLIGHT CONTROL BEARING PRESS SET



PN: FCBP-60-AA

Manufacturer: EAA Tools

Created to remove/install Flight Control Bearings and to resolve unknown rigging issues by identifying a faulty bearing. This tool significantly reduces labor hours during the Rig Inspection. It can also be used to measure drag torque on the bearings.

- Currently the only tool on the market to press out and check drag torque to the bearings.
- Significant time saver during aircraft rig by identifying a faulty bearing driving rigging issue.

Aircraft Application: H-60 A/G/L/M/V/W, S-70+/S-70i

System: Flight Control

Maintenance Level (US Army): FIELD

Material: Aluminum 6061-T6

Country of Origin: USA

Weights/Dimensions:

WT: 0.2 lbs

Size: 3"L x 1.3"W x 1.3"D



FLIGHT CONTROLS

THIN WALL 1/4" DRIVE, 3/8" DEEP WELL SOCKET



PN: SWD-60-AA

Manufacturer: Snap-On

Tool is used to remove/install Collective Balance Spring Hardware.

- 12 point configuration.
- Nickel-chrome finish helps protect against corrosion and makes it easy to wipe clean.

Aircraft Application: H-60 A/G/L/M/V/W, S-70+/S-70i

System: Collective Balance Spring

Maintenance Level (US Army): FIELD

Country of Origin: USA

Weights/Dimensions:

WT: 0.1 lbs

Size: 1.7"L x 0.7"W x 0.7"D



FLIGHT CONTROLS

HYDRAULIC SERVICE KIT



PN: BSD-60-AA

Manufacturer: EAA Tools

The EAA Tools Hydraulic Service Kit has all the correct components to perform all hydraulic servicing tasks on the aircraft, in one all-inclusive accountable and portable kit. The kit eliminates the need to search for all components needed to service. Each hydraulic hose assembly has been re-engineered from the ground up with the end user in mind, simplifying and accelerating each procedure.

- The only portal Brake-Strut-Damper Servicing kit on the market.
- Kit provides a significant labor reduction due to having a complete portable and inventoriable hydraulic service kit with everything included to perform brake, strut and damper bleeding and servicing.

Aircraft Application: H-60 A/G/L/M/V/W, S-70+/S-70i

System: Main Rotor Spindle Bolt Torque

Maintenance Level (US Army): FIELD

Country of Origin: USA

Weights/Dimensions:

WT: 7.0 lbs

Size: 3"L x 1.2"W x 0.5"D

MAIN LANDING GEAR STRUT TORQUE ADAPTER



PN: STA-60-AA

Manufacturer: EAA Tools

EAA Strut Torque Adapter design provides a high strength engineered special tool for precise fit and function to reach and break the torque of the lower Strut securing nut.

- Eliminates the need to remove the Brake Assembly to remove the MLG Strut making this a significant labor reduction task.
- Added to supplement the STA-60-AA is the 1-7/16" 1/2" drive socket to improve the efficiency of the STA-60-AA. The maintainer can remove and install the whole MLG Strut.
- The only special tool to remove the lower strut on the market.
- Nickel plated for corrosion prevention per MIL-STD.

Aircraft Application: H-60 A/G/L/M/V/W, S-70+/S-70i

System: Main Landing Gear

Maintenance Level (US Army): FIELD

Material: Hardened AISI 4140 Alloy Steel

Weights/Dimensions:

WT: 10.4 oz

Size: 5.5"L x 1.75"W x 1.4"D

MAIN LANDING GEAR STRUT PRESSURE GAUGE SET



PN: SPG-60-AA

Manufacturer: TronAir

Strut Pressure Gauge used to accurately service the exact N2 pressure in the Strut, includes a 90-degree offset adapter for exact fit to reduce the risk of strut failure due to improper/incorrect servicing.

Pressure Range: 0-3,000 psi (0-207 bar)

Increments: 50 psi (3.4 bar)

Hose Length: 16" (41 cm)

Includes: Coupler and 90 degree valve

Aircraft Application: H-60 A/G/L/M/V/W, S-70+/S-70i

System: Landing Gear

Maintenance Level (US Army): FIELD

Weights/Dimensions:

WT: 12.5 oz

Size: (Container) 7.5H x 17.5W x 3.5D

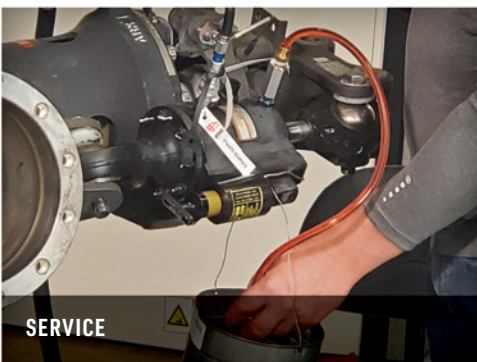

SERVICE



LANDING GEAR

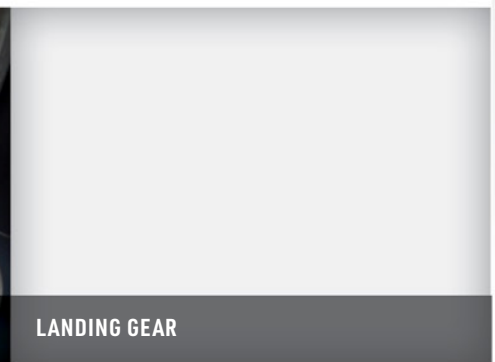

LANDING GEAR

TAIL YOKE TEFLON WASHER ALIGNMENT JIG



PN: TYT-60-AA

Manufacturer: EAA Tools

EAA Tools TYT prevents all misalignments of the Teflon washer re-bond task and ensures correct bond alignment.

- Using the TYT will help reduce labor by ensuring the Teflon washers are correctly aligned and bonded by not being able to over-tighten which can squeeze out the adhesive.
- This tool is a safety improvement. It ensures the Aft Main Mod Mount Bolts under the Rotor Brake are torque-checked.
- The tool decreases aircraft down-time, and decreases overall cost of maintenance (labor and material).
- The only special tool on the market for this task.

Aircraft Application: H-60 A/G/L/M/V/W, S-70+/S-70i

System: Tail Yoke

Maintenance Level (US Army): FIELD

Material: Delrin

Country of Origin: USA

Weights/Dimensions:

WT: 2.4 lbs

Size: 9.25"L x 4.75"W x 4.75"D

2-1/4" SOCKET, MAIN LANDING GEAR WITH 1/2" DRIVE ADAPTER



PN: MLGS-60-AA

Manufacturer: Snap-On

Large 2-1/4" Socket used to remove and install the main landing gear retaining nut. Included is the 1/2" female x 3/4" male adapter to fit on the 1/2" drive torque.

- This powerful socket has a regular depth size and a 2-1/4 in. 12 point opening.
- The 12 contact points ensure a solid grasp on the fastener.
- This steel socket is easy to keep clean.

Aircraft Application: H-60 A/G/L/M/V/W, S-70+/S-70i

System: Main Landing Gear

Maintenance Level (US Army): FIELD

Country of Origin: USA

Weights/Dimensions:

WT: 1.8 lbs

Size: 4.0"L x 3.0"W x 3.0"D

1"-7/16" 1/2" DRIVE SOCKET FOR LANDING GEAR STRUT



PN: SLGS-60-AA

Manufacturer: Snap-On

Socket that works with the STA-60-AA, Main Landing Gear Strut Hardware install/removal.

- 12 point configuration.
- Nickel-chrome finish helps protect against corrosion and makes it easy to wipe clean.

Aircraft Application: H-60 A/G/L/M/V/W, S-70+/S-70i

System: Main Landing Gear Strut

Maintenance Level (US Army): FIELD

Country of Origin: USA

Weights/Dimensions:

WT: 0.4 lbs

Size: 2.25"L x 1.25"W x 2.0"D

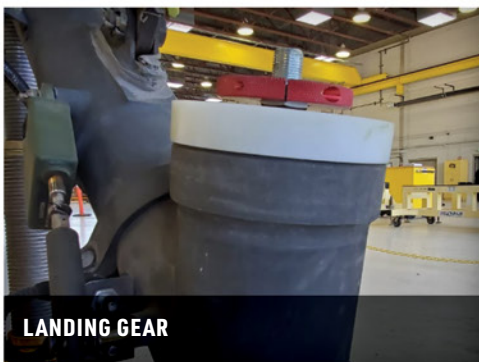

LANDING GEAR



LANDING GEAR



LANDING GEAR

MAIN ROTOR RETAINING NUT 20" 1/2" DRIVE EXTENSION



PN: DE-60-AA

Manufacturer: Snap-On

Assists in Main Rotor Head Zone 1 Hardware Installation/Torque Checks.

- 1/2" drive 20" extension helps you work in confined, hard-to-reach places.
- Offers additional leverage for stubborn rusted, corroded hardware.

Aircraft Application: H-60 A/G/L/M/V/W, S-70+/S-70i

System: Main Rotor Head

Maintenance Level (US Army): FIELD

Country of Origin: USA

Weights/Dimensions:

WT: 1.4 lbs

Size: 21.5"L x 1"W x 0.5"D



MAIN ROTOR

FIXTURE BRACE SET FOR BIFILAR WEIGHTS BOLTS (15/16" & 1-1/16)



PN: FBBW-60-AA

Manufacturer: EAA Tools

EAA Fixture Brace for Bifilar Weights Bolts Tool assists in applying torque to the Bifilar Weight Bolts (size varies by a/c tail#). This tool increases efficiency and effectiveness while reducing risk of injury.

- This tool reduces risk of drop damage on the Bifilar arms through its simple one tool design.
- Compact single tool provides reduction of labor as a one-person operation.
- Nickel plated for corrosion prevention per MIL-STD.

Aircraft Application: H-60 A/G/L/M/V/W, S-70+/S-70i

System: Main Rotor Head

Maintenance Level (US Army): FIELD

Material: Hardened AISI 4140 Alloy Steel

Country of Origin: USA

Weights/Dimensions:

WT: 0.3 lbs

Size: 6.5"L x 1.75"W x 0.25"D



MAIN ROTOR

PITCH CHANGE ROD TORQUE ADAPTER



PN: PRTA-60-AA

Manufacturer: EAA Tools

EAA Pitch Change Rod Torque Adapter Tool is used to install Pitch Control Rod Bolts to Required Torque Specification.

- Made with O1 Steel/Rockwell hardness HRC 62, rated for 1,800 inch lbs yield strength.
- Nickel plated for corrosion prevention per MIL-STD.

Aircraft Application: H-60 A/G/L/M/V/W, S-70+/S-70i

System: Pitch Change Rod

Maintenance Level (US Army): FIELD

Material: S7 Tool Steel

Country of Origin: USA

Weights/Dimensions:

WT: 0.25 lbs

Size: 3.75"L x 1.50"W x 0.313"D



MAIN ROTOR

SPINDLE & BLADE CUFF WASHER ALIGNMENT TOOL SET



PN: SBCAT-60-AA

Manufacturer: EAA Tools

This unique tool was designed to bond the Main Rotor Blade and Spindle Cuff Washers. It is efficiently designed to simultaneously apply pressure to the blade/spindle cuff washer while pushing the alignment insert out of the way, preventing inadvertent bonding of the insert to the washer/cuff.

- Eliminates the washers being inadvertently knocked off during the removal, installation and folding of the spindle and blades.
- Prevents unwanted bonding and isolates only the bonding of the washer to the cuff.
- Two pressure plates and individually-dimensioned blade and spindle Delrin alignment inserts simultaneously apply pressure to the washer allowing the pressure plates to clamp up the washer evenly.

Aircraft Application: H-60 A/G/L/M/V/W, S-70+/S-70i

System: Main Rotor Blade and Spindle Cuff Washer Bonding

Maintenance Level (US Army): FIELD

Material: Aluminum 6061-T6, Delrin

Country of Origin: USA

Weights/Dimensions:

WT: 0.2 lbs

Size: 3"L x 1.7"W x 1.7"D

BLADE ALIGNMENT TOOL



PN: BAT-60-AA

Manufacturer: EAA Tools

AA Blade Alignment Tool is used to align the Main Rotor Blade to the Spindle Cuff.

- Ergonomically redesigned handle prevents the tool from slipping through the blade and spindle cuff, eliminating the risk of drop damage to the aircraft fairings.
- Nickel plated for corrosion prevention per MIL-STD.

Aircraft Application: H-60 A/G/L/M/V/W, S-70+/S-70i

System: Main Rotor Hub and Blade

Maintenance Level (US Army): FIELD

Material: Hardened AISI 4140 Alloy Steel

Country of Origin: USA

Weights/Dimensions:

WT: 2.6 lbs

Size: 17"L x 1.0"W x 1.3"D

MAIN ROTOR BUSHING ALIGNMENT TOOL SET



PN: RBAT-60-AA

Manufacturer: EAA Tools

EAA Main Rotor Bushing Alignment Tool aligns bushings to the Main Rotor Blade Cuff.

- Nickel plated for corrosion prevention per MIL-STD.

Aircraft Application: H-60 A/G/L/M/V/W, S-70+/S-70i

System: Main Rotor Blade Cuff

Maintenance Level (US Army): FIELD

Material: Hardened AISI 4140 Alloy Steel

Country of Origin: USA

Weights/Dimensions:

WT: 1.4 lbs

Size: 6"L x 1.5"W x 1.5"D

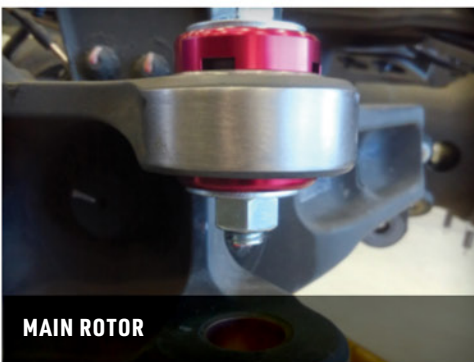

MAIN ROTOR

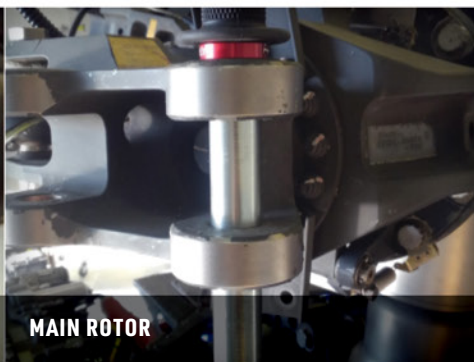

MAIN ROTOR



MAIN ROTOR

THREADED INSERT REPLACEMENT KIT



PN: TIRK-60-AA

Manufacturer: EAA Tools

EAA created the TIRK to have an appropriately sized custom hex set to remove & install threaded inserts on the M/R Head. It also installs the stainless steel and titanium Allen keys for balancing the improved Hi-Speed Shaft. Comes in G60 Pelican Utility Case.

- Provides the appropriate and correct sized Allen Key hardware.
- Eliminates the need to make home-made tools that are not exact.
- Eliminates the risk for slippage of the part or tool.
- Eliminates the risk of a non-precise tool causing the part to become unusable, leading to replacement cost and added labor.

Aircraft Application: H-60 A/G/L/M/V/W, S-70+/S-70i

System: Damper Bracket Retention, Lower Pressure Plate Retention, M/R Spindle Retention, Hi-speed Shaft (HSS Balance hardware inserts.)

Maintenance Level (US Army): FIELD

Country of Origin: USA

Weights/Dimensions:

WT: 1.8 lbs

Size: 9.5" L x 5" W x 2" D

BLADE LIFT CRADLE



PN: BLC-60-AA

Manufacturer: EAA Tools

EAA created the BLC to replace the legacy die-cast aluminum main rotor metal blade clamp. The EAA BLC is a red anodized machined 6061 aluminum assembly with an adjustable custom cantilever pivot clamping plate that fits to the contour of the blade. This provides optimum security and safety to lift with attached overhead lifting ring. For A&L Model Main Rotor Blades. To be used with a cargo safety strap.

Aircraft Application: H-60 A/G/L/M/V/W, S-70+/S-70i

System: Main Rotor Blade

Maintenance Level (US Army): FIELD

Material: Aluminum 60601-T6

Country of Origin: USA

Weights/Dimensions:

WT: 24 lbs

Size: 15" L x 11" W x 11" D

DAMPER SPHERICAL BEARING PRESS



PN: DSBP-60-AA

Manufacturer: EAA Tools

EAA DSBP is designed to remove the Spherical Damper Bearing that can be used without the need to disconnect the Damper from the aircraft, if needed. Can be used without the need for an Arbor Press in the field, thus saving labor and maintenance down time.

- Significantly reduces maintenance time.

Aircraft Application: H-60 A/G/L/M/V/W, S-70+/S-70i

System: Main Rotor Damper

Maintenance Level (US Army): FIELD

Material: Hardened AISI 4140 Alloy Steel

Country of Origin: USA

Weights/Dimensions:

WT: 3.2 lbs

Size: 11" L x 3.5" W x 3.5" D



MAIN ROTOR



MAIN ROTOR



MAIN ROTOR

SPINDLE BEARING PRESS SET



PN: SBP-60-AA

Manufacturer: EAA Tools

Redesigned to reduce the risk of the Press slipping off the bearing edge while using an arbor press to remove the bearing. The guide surface was lengthened by 1.0" to maximize the contact surface area with the edge of the bearing.

The Spindle Bearing Press Kit also uses a stainless-steel stand work-aid to prevent wobble to the Spindle while performing the press task. These improvements of the original design will greatly increase the efficacy of the press while reducing the risk of accidental damage to the Spindle Elastomeric Bearing.

Kit includes:

1. Spindle Bearing Installation
2. Spindle Bearing Removal
3. Stainless-Steel Stand

Aircraft Application: H-60 A/G/L/M/V/W, S-70+/S-70i

System: Main Rotor Spindle Bearing Install

Maintenance Level (US Army): FIELD

Material: Aluminum 6061-T6 and 304 Stainless Steel

Country of Origin: USA

Weights/Dimensions:

WT: 4.2 lbs

Size: 10"L x 5"W x 5"D

SWASHPLATE SCISSOR BEARING PRESS SET



PN: SSBP-60-AA

Manufacturer: EAA Tools

EAA SSBP is designed to remove and install the Swashplate Scissor Bearing.

- Nickel plated for corrosion prevention per MIL-STD.

Aircraft Application: H-60 A/G/L/M/V/W, S-70+/S-70i

System: Main Rotor Swashplate Scissor Bearing

Maintenance Level (US Army): FIELD

Material: Hardened AISI 4140 Alloy Steel

Country of Origin: USA

Weights/Dimensions:

WT: 5.5 lbs

Size: 6.5H x 4.4W x 2.2D

SPINDLE PULLER SET



PN: SP-60-AA

Manufacturer: EAA Tools

EAA Spindle Puller design and use is to gently and evenly pull the spindle from the Hub. As a one-person task, it is designed to control the removal of the spindle, even if stuck due to corrosion or abrasion. Procedure 2-3 minutes.

- Eliminates the need to strike the spindle in any way.
- Reduces the need to put undue force on the elastomeric bearings; only long enough to remove the two bolts from underneath the Pitch Arm.
- Eliminates the requirement to remove the Pro-Seal from Hub and Spindle.
- Includes a safety strap to prevent Spindle from dropping when removed from the Hub.
- Spindle Puller Back Plate has handles built in to allow remover to safely transport the (80+lb) Spindle down from the aircraft to the workbench.

Aircraft Application: H-60 A/G/L/M/V/W, S-70+/S-70i

System: Main Rotor Blade Hub and Spindle Assembly Removal

Maintenance Level (US Army): FIELD

Material: Aluminum 6061-T6 and Stainless Steel

Country of Origin: USA

NSN: 5120-01-710-9497

Weights/Dimensions:

WT: 20lbs (30 lbs with replacement components)

Size: 15"H x 11"W x 16"D



MAIN ROTOR

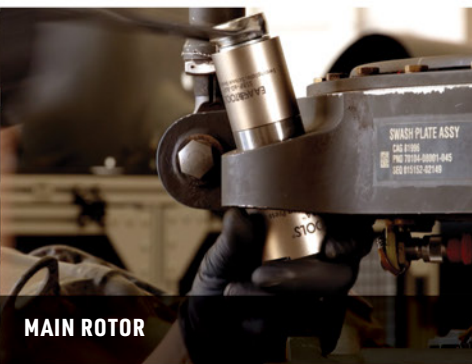

MAIN ROTOR



MAIN ROTOR

9/16" LOW PROFILE SOCKET FOR LOWER PRESSURE PLATE BOLTS



PN: LPP-60-AA
Manufacturer: Snap-On

Compact for tight areas.

- 12 point configuration.
- Nickel-chrome finish helps protect against corrosion and makes it easy to wipe clean.

Aircraft Application: H-60 A/G/L/M/V/W, S-70+/S-70i
System: Lower Pressure Plate
Maintenance Level (US Army): FIELD
Country of Origin: USA
Weights/Dimensions:
WT: 0.3 lbs
Size: 1"L x 1"W x 1"D

3/4" DRIVE, 11/16" SOCKET FOR MAIN MODULE HARDWARE



PN: MMS-60-AA
Manufacturer: Snap-On

Socket to accommodate 3/4" Drive Foot Pound Torque Wrench.

- Flank Drive® wrenching system delivers up to 20% more turning power without slipping or rounding while exceeding ANSI® performance standards.
- 12 point configuration.
- Industrial Finish.

Aircraft Application: H-60 A/G/L/M/V/W, S-70+/S-70i
System: Main Rotor Spindle Bolt Torque
Maintenance Level (US Army): FIELD
Weights/Dimensions:
WT: 1 lbs
Size: 2"L x 1.6"W x 1.6"D

PILOT SEAT RESILIENT MOUNT PRESS SET

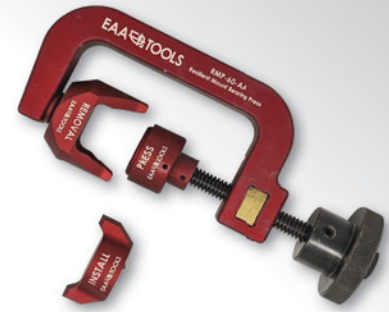

PN: RMP-60-AA
Manufacturer: EAA Tools

EAA created the RMP to easily remove & install the Pilot's Seat Elastomeric Isolators for use in only non-armored seat configuration.

- One of a kind tool for Pilot Seat Elastomeric Isolators.
- Using the RMP will help increase mission capability rates by effectively and reliably removing a Resilient Mount.
- Damaged resilient mounts may now be pressed out without time-consuming trial-and-error or replacing entire rail, resulting in increased up-time, and decreased overall cost of maintenance (labor and material).

Aircraft Application: H-60 A/G/L/M/V/W, S-70+/S-70i
System: Pilot Seat
Maintenance Level (US Army): FIELD
Material: Aluminum 6061-T6 and 7075-T6
Country of Origin: USA
Weights/Dimensions:
WT: 1.5 lbs
Size: 10"L x 4"W x 1.2"D



MAIN ROTOR



MAIN ROTOR

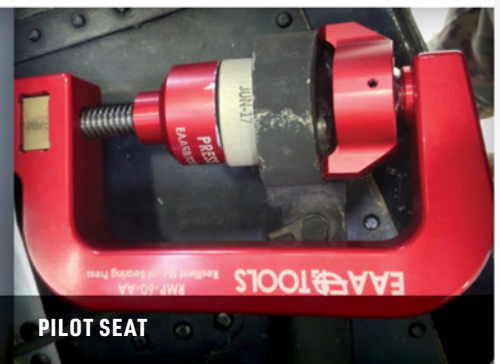

PILOT SEAT

TAIL ROTOR STAR PLATE



PN: TRSP-60-AA

Manufacturer: EAA Tools

Organize and Retain Tail Rotor Bolts, Balance Weights and Shimming.

- EAA Tools Tail Rotor Star Plate comes with hooks to safely hang on aircraft.

Aircraft Application: H-60 A/G/L/M/V/W, S-70+/S-70i

System: Tail Rotor Mount

Maintenance Level (US Army): FIELD

Material: Cast Clear Acrylic

Country of Origin: USA

Weights/Dimensions:

WT: 2.4 lbs

Size: 12"H x 11"W x 3.25"D



TAIL ROTOR

TAIL ROTOR ASSEMBLY INSPECTION TOOL



PN: TRAITAL-60-AA or TRAITM-60-AA

Manufacturer: EAA Tools

Tail Rotor one-piece, multi-function inspection guide to effectively check tolerances in the De-Ice stationary and rotating distributor and the IVHMS Tail Rotor Magnetic Pick-Up Interrupter gap tolerances. It is used to quickly check the retention plate mounting bolt thread exposure tolerances. Each gauge surface is calibrated with certified NIST-traceable inspection equipment. A certificate of compliance including high precision dimensions is included.

- Ensures all required inspection measurements are precision-calibrated without a need to double-check.
- Eliminates human error and thus duplicitous maintenance due to initial incorrect maintenance found in the QC process. Reduction in errors to de-ice distributors, preventing the tear-down of the inboard and outboard retention plates to gain access.

Aircraft Application: H-60 A/G/L/M/V/W, S-70+/S-70i

System: Tail Rotor Mount

Maintenance Level (US Army): FIELD

Material: 17-4PH Stainless Steel

Country of Origin: USA

Weights/Dimensions:

WT: 2.4 oz

Size: 12"H x 11"W x 3.25"D



TAIL ROTOR

TAIL ROTOR PITCH BEAM NUT SPANNER



PN: PBS-60-AA

Manufacturer: EAA Tools

EAA Version of T/R Spanner Nut offers the proper fit and function tool to safely and effectively remove/install the Nut. This tool ensures all required inspection measurements are precision-calibrated without a need to double-check. Using the correct tool will help increase mission capability rates, reduce risk of damage to aircraft, reduce the risk of injury to the maintainer, and decrease overall cost of maintenance (labor and material).

- Prevents the replacement of the Nut. Hole on Nut gets elongated due to using incorrect size spanner.
- If incorrect size is used, it can slip off the nut, causing a drop damage hazard to tools on the stabilator, falling hazard and/or injury due to spanner slipping off the nut while a large force is applied.

Aircraft Application: H-60 A/G/L/M/V/W, S-70+/S-70i

System: Tail Rotor

Maintenance Level (US Army): FIELD

Material: Hardened AISI 4140 Alloy Steel

Country of Origin: USA

Weights/Dimensions:

WT: 0.3 lbs

Size: 4"L x 2"W x 0.3"D

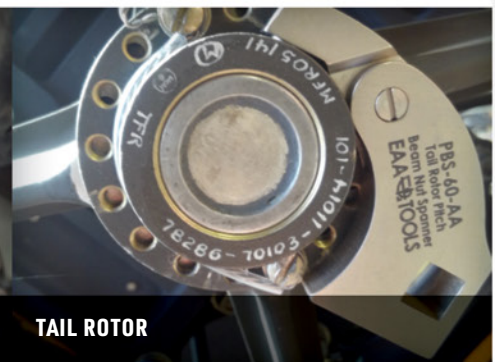

TAIL ROTOR

TAIL ROTOR PITCH BEAM PULLER



PN: PBP-60-AA

Manufacturer: EAA Tools

EAA Pitch Beam Puller is an improved interface to the aircraft with improvements in ergonomics, function, safety, weight reduction, and significant mechanical advantage. A handle adds to the safety of the maintainer during removal. The tool always stays square to the Pitch Beam, and eliminates the need to use an open-end wrench.

- Interface improvement eliminates human error- new design will not come apart during use by over adjusting parallel bolts and tool is always square with Pitch Beam.
- Additional mechanical advantage by using ACME thread and improved cantilever design.
- Mechanical operation improvement with addition of hand hold to the outboard portion of puller and eliminating the use of an open-end wrench.

Aircraft Application: H-60 A/G/L/M/V/W, S-70+/S-70i

System: Tail Rotor

Maintenance Level (US Army): FIELD

Material: Hardened AISI 4140 Alloy Steel, Stainless Steel

Country of Origin: USA

Weights/Dimensions:

WT: 11.4 lbs

Size: 11.5"H x 10"W x 2"D

TURNBUCKLE RIGGING KIT



PN: TRK-60-AA

Manufacturer: Snap-On

Adjusting cable turnbuckles no longer has to be a dreaded ordeal, and you won't need three hands to do it. With the Turnbuckle Rigging Kit you'll get a complete solution that consists of the Turnbuckle Rigging Tool to hold the terminal ends of the turnbuckle in place and keep the cable from twisting as you turn the barrel. And you also get our new Turnbuckle Wrench to make turning the barrel a piece of cake. The wrench clamps around the barrel (MS21251 style) and gives you the leverage to effortlessly turn it. This kit is a real timesaver that will let you adjust turnbuckles through inspection holes quickly and with minimal effort.

Aircraft Application: H-60 A/G/L/M/V/W, S-70+/S-70i

System: Tail Rotor Turnbuckles and Cables

Maintenance Level (US Army): FIELD

Weights/Dimensions:

WT: 0.3 lbs

Size: 12.5"H x 2"W x 0.7"D

TAIL ROTOR QUICK DISCONNECT WRENCH



PN: TRQD-60-AA

Manufacturer: EAA Tools

EAA Tools TRQD is used to quick disconnect tail rotor cable during A/C fold procedure.

- Tool solves the confined space issue.
- Minimized potential damage to hydraulic lines and other critical components.

Aircraft Application: H-60 A/G/L/M/V/W, S-70+/S-70i

System: Tail Rotor

Maintenance Level (US Army): FIELD

Material: 6061 Alloy Steel

Country of Origin: USA

Weights/Dimensions:

WT: 0.5 lbs

Size: 3"H x 1"W x 1.5"D

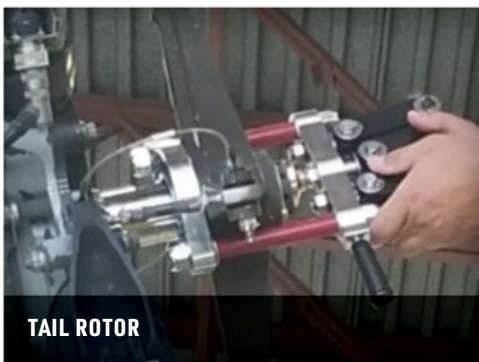

TAIL ROTOR



TAIL ROTOR

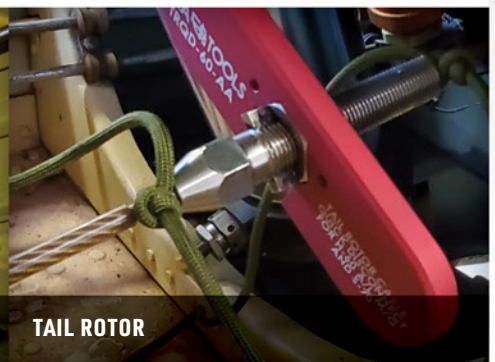

TAIL ROTOR

OUTBOARD RETENTION PLATE CENTER BUSHING TOOL



PN: CBP-60-AA

Manufacturer: EAA Tools

The Outboard Retention Plate Center Bushing Tool provides a uniform method to removing and installing Pilot Bushing from Outboard Retention Plate.

- Properly fit die to remove the center bushing in an arbor press.

Aircraft Application: H-60 A/G/L/M/V/W, S-70+/S-70i

System: Tail Rotor

Maintenance Level (US Army): FIELD

Material: 4140 Alloy Steel

Country of Origin: USA

Weights/Dimensions:

WT: 1.84 lbs

Size: 2.6H x 2.6W x 2.75D



TAIL ROTOR

AFT MAIN MOD MOUNT BOLT TORQUE ADAPTER



PN: RBTA-60-AA

Manufacturer: EAA Tools

EAA Tools Custom Torque Adapter removes aft L/H Main Mod Mount bolt and performs the 9-11 torque checks with efficiency by eliminating the need to remove the driveshaft and rotor brake hardware.

- Eliminates the need to remove the Rotor Brake and HSS when having to perform the 9-11 torque checks on the aft Main Mount Bolts.
- Improves safety by ensuring the Aft Main Mod Mount Bolts under the Rotor Brake are torque-checked.
- Nickel plated for corrosion prevention per MIL-STD.

Aircraft Application: H-60 A/G/L/M/V/W, S-70+/S-70i

System: Pylon Mount

Maintenance Level (US Army): FIELD

Material: Hardened AISI 4140 Alloy Steel

Country of Origin: USA

Weights/Dimensions:

WT: 1.2 lbs

Size: 8"H x 1"W x .5"D

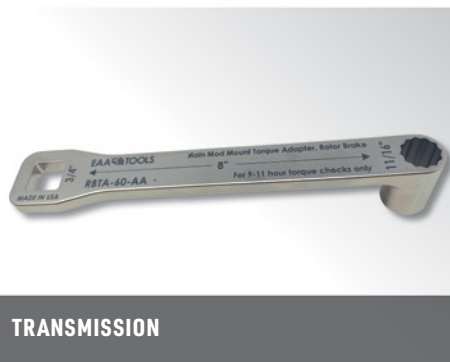

TRANSMISSION

XMSN CHIP DETECTOR REMOVAL TOOL



PN: CDR-60-AA

Manufacturer: EAA Tools

EAA Tools invented tool to effectively shut off the flow on the XMSN Chip Detector and provide a safe prying function to remove the chip detector without risk of damage to components, risk to mission, or need for additional persons and tools. This tool is compact and easy to take during aircraft operation when cautionary XMSN chip lights happen. Tool is designed to fit precisely on the chip detector sleeve and rotate the strainer to the ON or OFF flow position. The tool's prying function is then used to ease chip detector away from transmission sump, breaking the hydraulic suction lock.

- Reduces damage to the main module chip detector and transmission sump case half component occurring due to improper removal.
- The single operator uses only one hand to operate the UH-60 Chip Detector Removal Tool, allowing the other hand to be used to collect draining oil safely and easily.

Aircraft Application: H-60 A/G/L/M/V/W, S-70+/S-70i

System: Main Module Sump Chip Detector, Transmission

Maintenance Level (US Army): FIELD

Material: Aluminum 6061-T6

Country of Origin: USA

Weights/Dimensions:

WT: 0.3 lbs

Size: 5"H x 3"W x 5"D

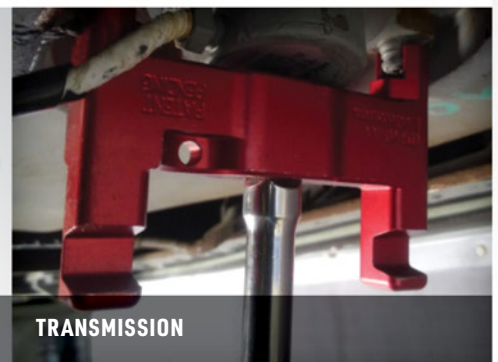

TRANSMISSION

MAIN MODULE XMSN OIL FILTER BOWL REMOVAL TOOL



PN: FBRA-60-AA and FBRLM-60-AA

Manufacturer: EAA Tools

The EAA FBRA/FBRLM tool provides a smooth dependable way to remove the filter bowl with a reduced risk of oil spillage. The FBRA-60-AA was designed specifically for the H-60 A model. The tool shuts off and removes the oil filter bowl.

- Prevents damage to the O-ring package on filter, protects filter bowl and shut-off sleeve dowel pin from damage and prevents damage to lower half of case mitigating risk of new XMSN.
- Significantly improves safety by preventing hot XMSN oil spillage on the maintainer and interior of the aircraft. Provides a controlled method to get past the packing and capture a quart of hot XMSN oil present in the bowl and line upon removal.
- Additional safety feature is the t-bar handle and filter clasp design. It was precisely designed with correct dimensions to provide the maintainer proper clearance and control to perform task correctly.
- It prevents shutoff sleeve dowel pin damage and combines two locally made items into one (A Model only).

Aircraft Application: H-60 A/G/L/M/V/W, S-70+/S-70i

System: Main Module Transmission

Maintenance Level (US Army): FIELD

Material: Aluminum 6061-T6, CRS Steel

Country of Origin: USA

NSN: 5120-01-714-3565

Weights/Dimensions:

WT: 1.7 lbs

Size: 8.5"H x 6"W x 6"D

GEARBOX SEAL REMOVAL TOOL



PN: GBSP-60-AA

Manufacturer: EAA Tools

New for 2023, the redesigned EAA tools Gearbox Seal Removal Tool which incorporates a slide hammer and a spline shaft guard, is used to properly remove all gearbox input and output seals. This tool is used throughout the TM1-1520-237-23 on every gearbox.

- Machined stainless steel with slide hammer to facilitate removal
- Delrin screw-on guard to protect the spline drive shafts.
- Standard tool that fits all sacrificial spline adapters.
- Only tool on the market for this function.

Aircraft Application: H-60 A/G/L/M/V/W, S-70+/S-70i

System: Drivetrain

Maintenance Level (US Army): FIELD

Material: Alloy Steel

Country of Origin: USA

Weights/Dimensions:

WT: 0.87 lbs

Size: 9.8H x 2.7W x 2.5D

GENERATOR SPLINE REMOVAL TOOL



PN: SRT-60-AA

Manufacturer: EAA Tools

The EAA Tools created Gearbox Spline Removal Tool removes Sacrificial Splines from Accessory Gearbox and APU. There is no other tool like this on the market.

- Reduces potential damage to gearbox and associated time to repair damage.
- Standardized tool eliminating picks and mitigating tool marks on gears.

Aircraft Application: H-60 A/G/L/M/V/W, S-70+/S-70i

System: APU/Accessory Gearbox

Maintenance Level (US Army): FIELD

Material: Hardened 4140 Alloy Steel

Country of Origin: USA

Weights/Dimensions:

WT: 0.57 lbs

Size: 6.25H x 5.0W x 0.5D



TRANSMISSION

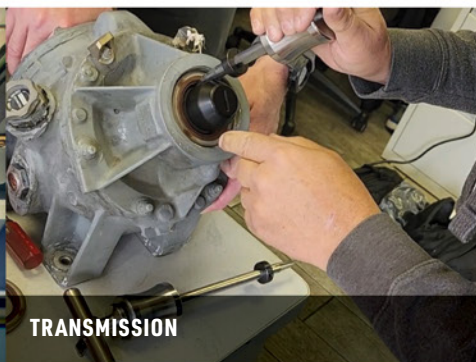

TRANSMISSION



GENERATOR

NOMINAL TRAMMEL TOOL



PN: NOM-60-AA

Manufacturer: EAA Tools

The Pitch Control Rod Nominal Lengths Gauge (NOM-60-AA) is used to set the lengths of the H-60 Pitch Control Rods prior to installation during a Main Rotor Rig. Using the NOM-60-AA to set rod lengths to nominal as defined by the US Army's Technical Manual will significantly reduce rig time and prevent costly and dangerous errors.

The latest upgrade includes a knurled brass knob set screw used as a Brake to custom-set the NOM-60-AA to the exact known-rigged aircraft rod lengths and apply to the replacement control rods, and per theory of operation, reduce the flight control Rig task time.

Aircraft Application: H-60 A/G/L/M/V/W, S-70+/S-70i

System: Flight Control

Maintenance Level (US Army): FIELD

Material: Stainless Steel and 6061-T6 Aluminum

Country of Origin: USA

Weights/Dimensions:

WT: 1.13 lbs

Size: 24" L x 3" W x 2.5" D

SPRING CYLINDER CLAMP



PN: SCC-60-AA

Manufacturer: EAA Tools

Tool SCC-60-AA is used to keep the Tail Rotor Spring Cylinders from compressing when they are disconnected. The tool is installed on the Spring Cylinders prior to disconnection from the Spring Cylinder Support and removed from the Spring Cylinders after reconnection to the Spring Cylinder Support.

Aircraft Application: H-60 A/G/L/M/V/W, S-70+/S-70i

System: Flight Control

Maintenance Level (US Army): FIELD

Material: Delrin

Country of Origin: USA

Weights/Dimensions:

WT: 8 oz ea (kit contains qty 2)

Size: .7" L x 2.5" W x 2.5" D

PITCH CHANGE LINK ELASTOMERIC ALIGNMENT TOOL

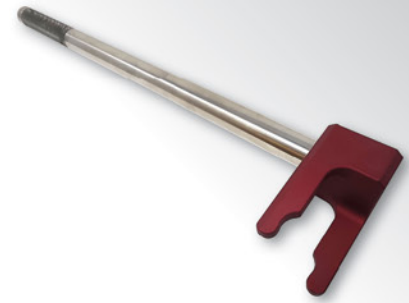

PN: PCLT-60-AA

Manufacturer: EAA Tools

The Pitch Change Link Tool, used to manipulate the PC Link Elastomeric Bearing during R&I, is a replacement to the US Army issued tool on the Original 237WP PTK. The legacy Army tool had the potential of damaging the Spindle Pitch Arm. EAA Tools has redesigned the tool Head of the current PTK tool, in order to accomplish the manipulation of the bearing without making contact with the Spindle Pitch Arm.

Aircraft Application: H-60 A/G/L/M/V/W, S-70+/S-70i

System: Main Rotor

Maintenance Level (US Army): FIELD

Material: Stainless Steel and 6061-T6 Aluminum

Country of Origin: USA

Weights/Dimensions:

WT: 7.5 lbs

Size: 21" L x 4.5" W x 2.25" D



FLIGHT CONTROL

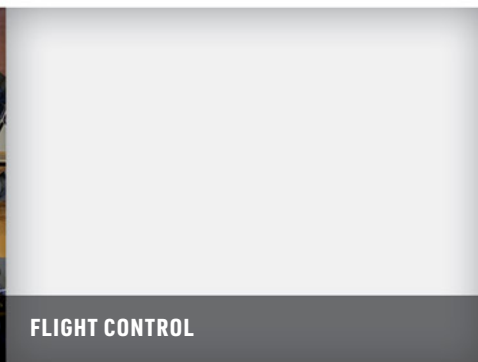

FLIGHT CONTROL

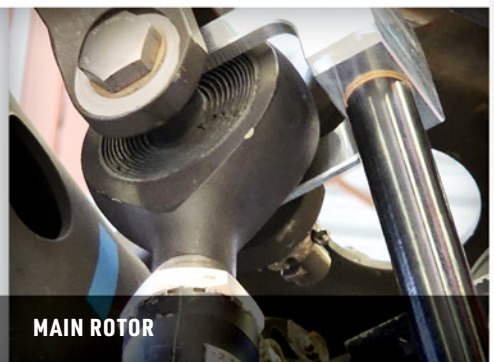

MAIN ROTOR

STABILATOR BOLT REMOVAL TOOL



PN: SRBT-60-AA

Manufacturer: EAA Tools

Removes a stuck rh/lh stabilator hinge fitting bolt.

Aircraft Application: H-60 A/G/L, S-70, S70+

System: Airframe

Maintenance Level (US Army): FIELD

Material: _____

Country of Origin: USA

Weights/Dimensions:

WT: 2.7 lbs

Size: 2.75" L x 8" W x .5" D

SEAL INSTALLATION TOOL SET

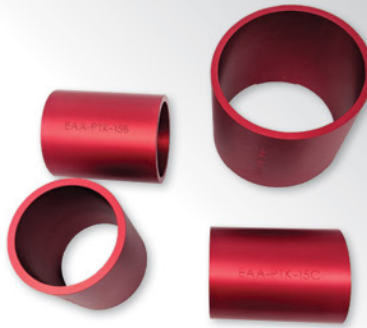

PN: SIT-60-AA

Manufacturer: EAA Tools

Input Mod (Input Seal) Installation Tool (EAA-SIT-01)

Main G/B (Output Seal) Installation Tool (EAA-SIT-02)

Tail Rotor G/B (Input Seal) Installation Tool (EAA-SIT-03)

Tail Rotor G/B (Output Seal) Installation Tool (EAA-SIT-04)

Aircraft Application: H-60 A/G/L/M/V/W, S-70+/S-70i

System: Transmission

Maintenance Level (US Army): FIELD

Material: 6061 Aluminum

Country of Origin: USA

Weights/Dimensions:

EAA-SIT-01

WT: 6 oz

Size: 3.5" L X 3.5" W X 4" D

EAA-SIT-02

WT: 14 oz

Size: 3.25" L X 3.25" W X 4" D

EAA-SIT-03

WT: 13 oz

Size: 3" L X 3" W X 4" D

EAA-SIT-04

WT: 1.25 oz

Size: 5" L x 5" W x 4" D

INPUT MODULE FLANGE PULLER



PN: FP-60-AA

Manufacturer: EAA Tools

Removes the flange off the Input Module.

Aircraft Application: H-60 A/G/L/M/V/W, S-70+/S-70i

System: Transmission

Maintenance Level (US Army): FIELD

Material: 4140 Alloy Steel

Country of Origin: USA

Weights/Dimensions:

WT: 2.7 lbs

Size: 10" L x 4" W x 4" H

AIRFRAME

TRANSMISSION

TRANSMISSION

SPINDLE PRY BAR, MAIN ROTOR HEAD (US NAVY)



PN: SPB-60-RS

Manufacturer: EAA Tools

The Spindle Pry Bar (SPB) is used to manipulate the Main Rotor Spindle during maintenance on the Main Rotor Head. Hydraulic hoses were required to be disconnected when using prior designs of the SPB, driving subsequent bleed and service actions. SPB-60-RS alleviates the need to disconnect hydraulic hoses and does not risk damage or impingement to the hydraulic hoses or adjacent components, thereby reducing maintenance man-hours and downtime compared to work required with prior SPB designs. The machined 6061 aluminum is lightweight and ergonomic, meticulously designed to exact form, fit and function for the task and approved for use by USN H-60 FST Engineering.

Aircraft Application: HH-60H, MH-60R, MH-60S,
SH-60B, SH-60F

System: Main Rotor Head Assembly

Maintenance Level (US Navy): Organizational

Material: 6061-T6 Aluminum

Country of Origin: USA

NSN: 3040-01-722-4706

Weights/Dimensions:

SPB WT: 21.20 lbs (with handle attached)

Dims: 70.0" L x 11.0" W x 11.0" H x 8.0" D
(w/ handle attached)

Wrench Head Only: 11" W x 11" H x 8.0" D

Handle: 64.0" L x 2.0" OD (1.50" ID)

LOCK PIN RATCHET WRENCH 7/8," FOLDING STABILATOR



PN: LPRW-60-AA

Manufacturer: Williams

Used during the folding procedure of the Horizontal Stabilator to vertically fold the stabilator at the lock pins and folding tail lock pins for air transportability.

Aircraft Application: H-60M/W

System: Horizontal Stabilator, Folding

Maintenance Level (US Army): FIELD

Material: High Carbon Steel

Country of Origin: USA

Weights/Dimensions:

WT: 0.60 lbs

Size: 9.50" L x 1.50" W

DRIVE LINE TORQUE REACTOR



PN: DLTR-60-EA

Manufacturer: EAA Tools

The Drive Line Torque Reactor is used to remove and install (R&I) the Tail Rotor and Oil Cooler Drive Flange Retaining Nut, to include performing the torque check inspection on the Oil Cooler Retaining Nut during the PMI-II inspection.

Aircraft Application: H-60 and S-70 Series Platform

Material: Pre-Hardened 4140 Alloy Steel

Country of Origin: USA

Weights/Dimensions:

WT: 5.20 lbs

Size: Drive Line Plate: 6.125" L x 6.125" H x 0.50" W
Drive Line Socket: 3/4" Drive, 2.625" Dia. x 1.625" L



MAIN ROTOR



HORIZONTAL STABILATOR, FOLDING

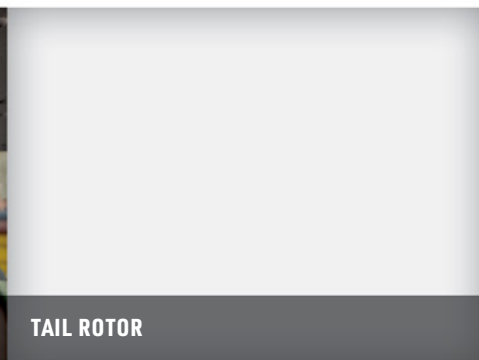

TAIL ROTOR

TAIL ROTOR PIVOT BEARING REPLACEMENT WRENCH



PN: PBRW-60-AA

Manufacturer: EAA Tools

The EAA Tools Pivot Bearing Replacement Wrench (3/8" 12pt Castellated) is specifically designed and geometrically angled to access and engage the Pivot Bearing Locknut at the T/R Hub.

Aircraft Application: H60 and S70 Platform

System: Tail Rotor Hub

Maintenance Level (US Army): FIELD

Material: Annealed alloy 4140 steel RHC 44,
Black Oxide plating

Country of Origin: USA

Weights/Dimensions:

WT: 0.4 lbs

Size: 10" L x 2" W x 0.25" T

TAIL ROTOR HUB

OUR QUALITY STATEMENT

EAA Tools Inc. commits itself to uncompromising Quality as its number one objective. Our Quality Policy is to:

Design, manufacture and market products that exhibit superior performance, reliability, durability and comfort that consistently meet or exceed the expectations of customers;

Continuously improve quality, while providing complete and on-time delivery of quality products and services, in the most effective manner possible;

Require each manager deliver uncompromising quality in his or her organization, product or service; Establish and communicate to responsible associates relevant quality performance metrics; requires each associate to assume responsibility and be accountable for improving the quality of his or her work;

Periodically review internal and external customer expectations and requirements.

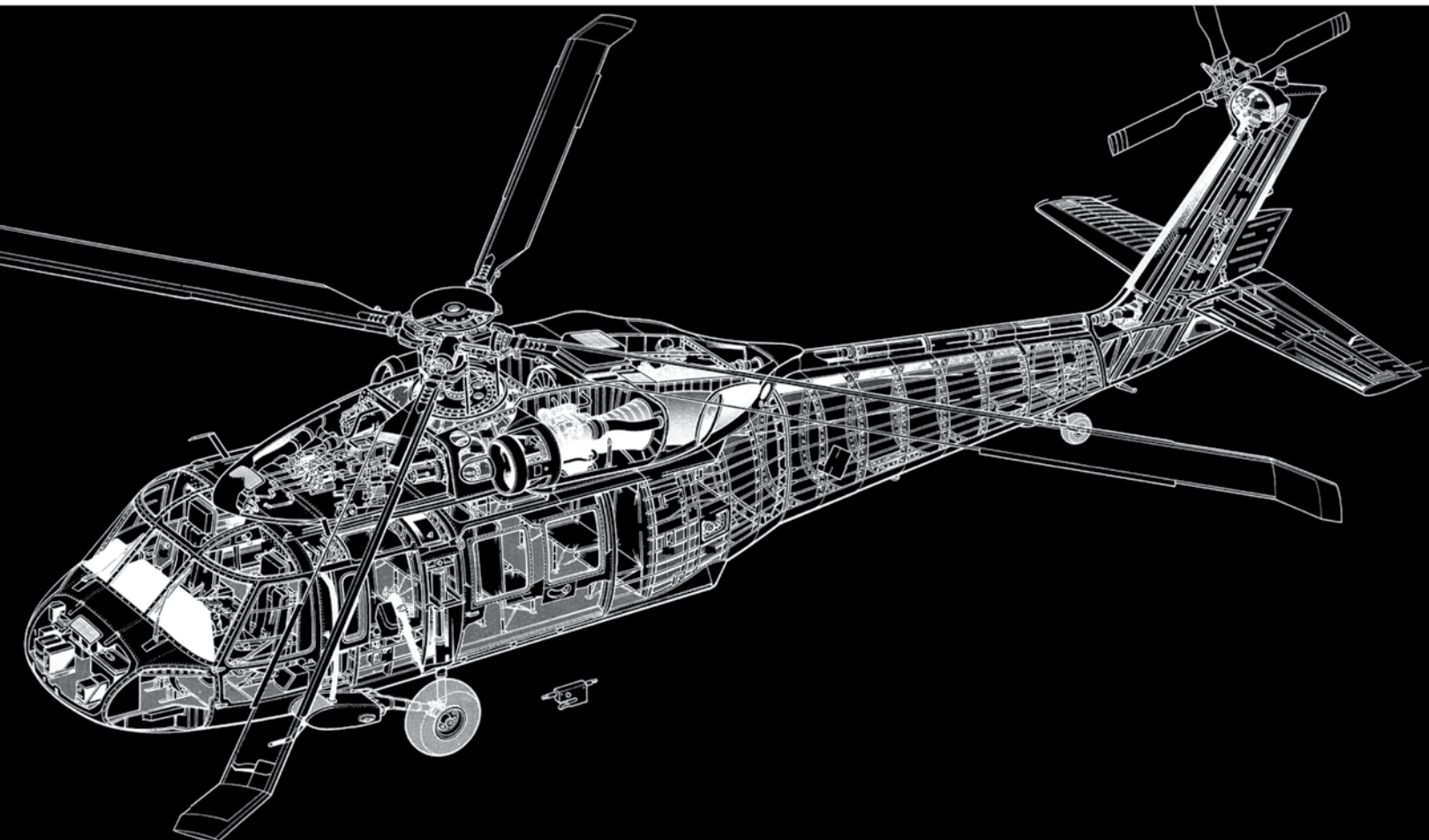

OUR WARRANTY

OFFER AND GOVERNING PROVISIONS

EAA Tools, LLC ("EAA") is pleased to offer for sale the tools and equipment manufactured or marketed by EAA Tools ("Product"), subject to the following terms and conditions. Customer's placement of an order for a Product constitutes Customer's unconditional acceptance of the following terms and conditions. These terms and conditions are subject to change without prior written notice at any time and in EAA's sole discretion.

WARRANTY - PROFESSIONAL USE FOR PRODUCTS

EAA warrants to Customers who purchase Product from authorized EAA distribution channels for use in their profession that EAA brand Durable Products will be free from defects in workmanship and materials for a duration of five (5) years after date of sale. Consumable Products are warranted, at the time of sale, only against defects in workmanship or materials that prevent their use. Consumable products are goods reasonably expected to be used up or damaged during use, including but not limited to drill bits, saw blades, grinding discs, sanding discs, knife blades, files, O2 sensors and batteries. This warranty only extends to the original Customer and cannot be transferred or assigned.

During the applicable duration of the warranty, at its option, EAA will repair or replace its Products which fail to give satisfactory service due to defective workmanship or materials or provide a refund by repaying or crediting Customer with an amount equal to the purchase price of such Products. Repair, replacement or refund shall be at the election and expense of EAA and is Customer's exclusive remedy in place of all other rights and remedies. Any products or parts replaced or for which EAA has provided a refund are the property of EAA and will not be returned. By repairing or replacing a Product, or providing a refund, EAA does not waive a claim that a Product nevertheless has been subject to abnormal use.

To obtain warranty service, contact the EAA Customer Care Center via telephone at 1-480-420-4044 or e-mail sales@eaa.tools. The following information will be required with the customer's warranty request: (1) date and proof of purchase, (2) where customer purchased the product, (3) full name, (4) shipping address, (5) phone number, (6) e-mail address, (7) item number(s) or approximate weight of return package. Warranty requests that do not include all of the required information will not be processed. Once the warranty request is validated, the customer will be sent a shipping label either electronically thru e-mail or thru the U.S. mail, and must ship the product to EAA. Upon receipt of the product, the warranty claim will be reviewed, and the product will be inspected. If the warranty request is found to be valid, the product will be repaired and returned to the customer or a replacement product will be shipped to the customer. If the warranty claims are found to be invalid, the original product will be returned to the customer. By repairing or replacing a Product, EAA does not waive a claim that a Product nevertheless has been subject to abnormal use. If you choose not to (1) use a carrier that offers tracking or (2) insure or declare the full value of the product, you will be responsible for any loss or damage to the product during shipping. Replacement will not be issued unless a valid proof of delivery can be provided.

In addition to any limitations outlined in warranty statements provided with the Product, EAA does NOT provide any warranty for (1) products labeled other than EAA or (2) products subjected to "abnormal use". Products that are not labeled EAA are subject to the warranty provided by the manufacturers of those products and EAA will pass along any such warranties. "Abnormal use" includes misuse, accident, modification, unreasonable use, abuse, neglect, lack of maintenance, use in product-related service, or use after the product is significantly worn. Abnormal use of tool storage units also includes, without limitation, situations when a unit is pulled using a mechanical vehicle, rolled over large drops, used in a highly corrosive environment, used as a step stool, modified with non-EAA parts, overloaded or modified in any way. THE FOREGOING WARRANTY IS IN LIEU OF AND EXCLUDES ALL OTHER WARRANTIES NOT EXPRESSLY SET FORTH HEREIN, WHETHER EXPRESS OR IMPLIED, BY OPERATION OF LAW OR OTHERWISE, INCLUDING BUT NOT LIMITED TO ANY IMPLIED WARRANTIES OF MERCHANTABILITY OR FITNESS FOR A PARTICULAR PURPOSE. Descriptions of Product contained in marketing material are for the sole purpose of identifying Product and shall not be construed as an express warranty.

*WARRANTY NOTE

Any modifications or changes made to the tool will void the warranty protection, and EAA Tools will not be responsible for repairs or replacements or damage due to issues arising from those alterations.

LIMITATION OF LIABILITY

EAA AND ITS AFFILIATED COMPANIES AND THIRD PARTY SUPPLIERS SHALL NOT BE LIABLE FOR ANY INCIDENTAL, SPECIAL OR CONSEQUENTIAL LOSSES, COSTS OR DAMAGES INCURRED BY BUYER OR OTHERS, DIRECTLY OR INDIRECTLY ARISING FROM THE SALE, HANDLING OR USE OF THE PRODUCTS, OR FROM ANY OTHER CAUSE WITH RESPECT TO THE PRODUCTS OR THE FOREGOING WARRANTY, WHETHER SUCH CLAIM IS BASED UPON BREACH OF CONTRACT, BREACH OF WARRANTY, STRICT LIABILITY IN TORT, NEGLIGENCE OR ANY OTHER LEGAL THEORY (INCLUDING WITHOUT LIMITATION, LOST PROFITS, REVENUES, ANTICIPATED SALES, BUSINESS OPPORTUNITIES, GOODWILL, OR INTERRUPTION OF BUSINESS OR OTHER INJURY OR DAMAGE).

NOTICE OF PRODUCT DESIGN

EAA reserves the right to make changes in design or construction at any time without incurring any obligation to incorporate such changes in Product previously sold. EAA also reserves the right to discontinue the manufacture or offering for sale of any Product at such time to be determined by EAA in its sole discretion.

SHIPPING; TITLE; RISK OF LOSS

Title to Product will pass from EAA or EAA's suppliers to Customer on shipment from EAA's facilities or other designated third party supplier's facility. Loss or damage that occurs during shipping by a carrier selected by EAA is EAA's or EAA's supplier's responsibility. Loss or damage that occurs during shipping by a carrier selected by Customer is Customer's responsibility. EAA reserves the right to make delivery of Product in installments.

In the event the shipment has not been received within 14 days of the billing (hard charge) to the credit card, the customer must contact EAA so a tracer can be initiated on the shipment. Typically, customers receive their parcel post and priority parcel post shipments within 10-14 business days, however parcel post shipments have been documented of up to 6-8 weeks for delivery. Tracers on shipments through the US Postal Service cannot be done until 8 weeks from the shipment date.

DELAY

EAA and its affiliates and third party suppliers shall not be liable for any damage as a result of any delay or failure to deliver due to any cause beyond EAA's or its third party supplier's reasonable control, including, without limitation, any act of God, act of Customer, embargo or other governmental act, regulation or request, fire, accident, strike, slowdown, war, riot, delay in transportation, or inability to obtain necessary labor, materials or manufacturing facilities. In the event of any such delay, the date of delivery shall be extended for a period equal to the time lost because of the delay. Customer's exclusive remedy for other delays and for EAA's or its third-party supplier's inability to deliver for any reason shall be rescission of the sale of Product.

GOVERNING LAWS

These terms and conditions shall be governed by and construed in accordance with the laws of the State of Arizona, without reference to principles of conflicts of laws. The rights and obligations of the parties hereunder shall not be governed by the 1980 U.N. Convention on Contracts for the International Sale of Goods. Any provision which is prohibited or unenforceable in any jurisdiction shall, as to such jurisdiction, be ineffective to the extent of such prohibition or unenforceability of such provision in any other jurisdiction.

EAA TOOLS®

EAA TOOLS INC

CAGE: 9PVP9 NAICS: 332216 UEI: TLYZRMQ825H7

Registered with SAM.gov, SBA.gov

Service-Disabled Veteran-Owned Small Business

info@eaatools.com eaa.tools (480) 420-4044

